

Software Manual



Application Firmware for Noise Figure and Gain Measurements for R&S[®] Analyzers

R&S[®] FS-K30
1300.6508.02

Printed in the Federal
Republic of Germany



This Software Manual describes the following models:

R&S®FSG

R&S®FSMR (only for ser. no. >200 000)

R&S®FSP

R&S®FSQ

R&S®FSU

R&S®FSUP

Dear Customer,

R&S® is a registered trademark of Rohde & Schwarz GmbH & Co. KG.

Trade names are trademarks of the owners.

Grouped Safety Messages









Make sure to read through and observe the following safety instructions!







All plants and locations of the Rohde & Schwarz group of companies make every effort to keep the safety standard of our products up to date and to offer our customers the highest possible degree of safety. Our products and the auxiliary equipment required for them are designed and tested in accordance with the relevant safety standards. Compliance with these standards is continuously monitored by our quality assurance system. The product described here has been designed and tested in accordance with the EC Certificate of Conformity and has left the manufacturer's plant in a condition fully complying with safety standards. To maintain this condition and to ensure safe operation, observe all instructions and warnings provided in this manual. If you have any questions regarding these safety instructions, the Rohde & Schwarz group of companies will be happy to answer them.

Furthermore, it is your responsibility to use the product in an appropriate manner. This product is designed for use solely in industrial and laboratory environments or, if expressly permitted, also in the field and must not be used in any way that may cause personal injury or property damage. You are responsible if the product is used for an intention other than its designated purpose or in disregard of the manufacturer's instructions. The manufacturer shall assume no responsibility for such use of the product.

The product is used for its designated purpose if it is used in accordance with its product documentation and within its performance limits (see data sheet, documentation, the following safety instructions). Using the product requires technical skills and a basic knowledge of English. It is therefore essential that only skilled and specialized staff or thoroughly trained personnel with the required skills be allowed to use the product. If personal safety gear is required for using Rohde & Schwarz products, this will be indicated at the appropriate place in the product documentation. Keep the basic safety instructions and the product documentation in a safe place and pass them on to the subsequent users.

Symbols and safety labels

							
Observe product documentation	Weight indication for units >18 kg	Danger of electric shock	Warning! Hot surface	PE terminal	Ground	Ground terminal	Attention! Electrostatic sensitive devices

					
Supply voltage ON/OFF	Standby indication	Direct current (DC)	Alternating current (AC)	Direct/alternating current (DC/AC)	Device fully protected by double/reinforced insulation

Observing the safety instructions will help prevent personal injury or damage of any kind caused by dangerous situations. Therefore, carefully read through and adhere to the following safety instructions before putting the product into operation. It is also absolutely essential to observe the additional safety instructions on personal safety that appear in relevant parts of the product documentation. In these safety instructions, the word "product" refers to all merchandise sold and distributed by the Rohde & Schwarz group of companies, including instruments, systems and all accessories.

Tags and their meaning

DANGER	DANGER indicates a hazardous situation which, if not avoided, will result in death or serious injury.
WARNING	WARNING indicates a hazardous situation which, if not avoided, could result in death or serious injury.
CAUTION	CAUTION indicates a hazardous situation which, if not avoided, may result in minor or moderate injury.
NOTICE	NOTICE indicates a property damage message.

In the product documentation, the word ATTENTION is used synonymously.

These tags are in accordance with the standard definition for civil applications in the European Economic Area. Definitions that deviate from the standard definition may also exist in other economic areas or military applications. It is therefore essential to make sure that the tags described here are always used only in connection with the related product documentation and the related product. The use of tags in connection with unrelated products or documentation can result in misinterpretation and thus contribute to personal injury or material damage.

Basic safety instructions

1. The product may be operated only under the operating conditions and in the positions specified by the manufacturer. Its ventilation must not be obstructed during operation. Unless otherwise specified, the following requirements apply to Rohde & Schwarz products:
prescribed operating position is always with the housing floor facing down, IP protection 2X, pollution severity 2, overvoltage category 2, use only in enclosed spaces, max. operation altitude 2000 m above sea level, max. transport altitude 4500 m above sea level.
A tolerance of $\pm 10\%$ shall apply to the nominal voltage and of $\pm 5\%$ to the nominal frequency.
2. Applicable local or national safety regulations and rules for the prevention of accidents must be observed in all work performed. The product may be opened only by authorized, specially trained personnel. Prior to performing any work on the product or opening the product, the product must be disconnected from the supply network. Any adjustments, replacements of parts, maintenance or repair must be carried out only by technical personnel authorized by Rohde & Schwarz. Only original parts may be used for replacing parts relevant to safety (e.g. power switches, power transformers, fuses). A safety test must always be performed after parts relevant to safety have been replaced (visual inspection, PE conductor test, insulation resistance measurement, leakage current measurement, functional test).
3. As with all industrially manufactured goods, the use of substances that induce an allergic reaction (allergens, e.g. nickel) such as aluminum cannot be generally excluded. If you develop an allergic reaction (such as a skin rash, frequent sneezing, red eyes or respiratory difficulties), consult a physician immediately to determine the cause.
4. If products/components are mechanically and/or thermally processed in a manner that goes beyond their intended use, hazardous substances (heavy-metal dust such as lead, beryllium, nickel) may be released. For this reason, the product may only be disassembled, e.g. for disposal purposes, by specially trained personnel. Improper disassembly may be hazardous to your health. National waste disposal regulations must be observed.

Grouped Safety Messages

5. If handling the product yields hazardous substances or fuels that must be disposed of in a special way, e.g. coolants or engine oils that must be replenished regularly, the safety instructions of the manufacturer of the hazardous substances or fuels and the applicable regional waste disposal regulations must be observed. Also observe the relevant safety instructions in the product documentation.
6. Depending on the function, certain products such as RF radio equipment can produce an elevated level of electromagnetic radiation. Considering that unborn life requires increased protection, pregnant women should be protected by appropriate measures. Persons with pacemakers may also be endangered by electromagnetic radiation. The employer/operator is required to assess workplaces where there is a special risk of exposure to radiation and, if necessary, take measures to avert the danger.
7. Operating the products requires special training and intense concentration. Make certain that persons who use the products are physically, mentally and emotionally fit enough to handle operating the products; otherwise injuries or material damage may occur. It is the responsibility of the employer to select suitable personnel for operating the products.
8. Prior to switching on the product, it must be ensured that the nominal voltage setting on the product matches the nominal voltage of the AC supply network. If a different voltage is to be set, the power fuse of the product may have to be changed accordingly.
9. In the case of products of safety class I with movable power cord and connector, operation is permitted only on sockets with earthing contact and protective earth connection.
10. Intentionally breaking the protective earth connection either in the feed line or in the product itself is not permitted. Doing so can result in the danger of an electric shock from the product. If extension cords or connector strips are implemented, they must be checked on a regular basis to ensure that they are safe to use.
11. If the product has no power switch for disconnection from the AC supply, the plug of the connecting cable is regarded as the disconnecting device. In such cases, it must be ensured that the power plug is easily reachable and accessible at all times (corresponding to the length of connecting cable, approx. 2 m). Functional or electronic switches are not suitable for providing disconnection from the AC supply. If products without power switches are integrated in racks or systems, a disconnecting device must be provided at the system level.
12. Never use the product if the power cable is damaged. Check the power cable on a regular basis to ensure that it is in proper operating condition. By taking appropriate safety measures and carefully laying the power cable, ensure that the cable cannot be damaged and that no one can be hurt by e.g. tripping over the cable or suffering an electric shock.
13. The product may be operated only from TN/TT supply networks fused with max. 16 A (higher fuse only after consulting with the Rohde & Schwarz group of companies).
14. Do not insert the plug into sockets that are dusty or dirty. Insert the plug firmly and all the way into the socket. Otherwise, this can result in sparks, fire and/or injuries.
15. Do not overload any sockets, extension cords or connector strips; doing so can cause fire or electric shocks.
16. For measurements in circuits with voltages $V_{\text{rms}} > 30 \text{ V}$, suitable measures (e.g. appropriate measuring equipment, fusing, current limiting, electrical separation, insulation) should be taken to avoid any hazards.
17. Ensure that the connections with information technology equipment comply with IEC 950/EN 60950.
18. Unless expressly permitted, never remove the cover or any part of the housing while the product is in operation. Doing so will expose circuits and components and can lead to injuries, fire or damage to the product.
19. If a product is to be permanently installed, the connection between the PE terminal on site and the product's PE conductor must be made first before any other connection is made. The product may be installed and connected only by a license electrician.

Grouped Safety Messages

20. For permanently installed equipment without built-in fuses, circuit breakers or similar protective devices, the supply circuit must be fused in such a way that suitable protection is provided for users and products.
21. Do not insert any objects into the openings in the housing that are not designed for this purpose. Never pour any liquids onto or into the housing. This can cause short circuits inside the product and/or electric shocks, fire or injuries.
22. Use suitable overvoltage protection to ensure that no overvoltage (such as that caused by a thunderstorm) can reach the product. Otherwise the operating personnel will be endangered by electric shocks.
23. Rohde & Schwarz products are not protected against penetration of liquids, unless otherwise specified (see also safety instruction 1.). If this is not taken into account, there exists the danger of electric shock for the user or damage to the product, which can also lead to personal injury.
24. Never use the product under conditions in which condensation has formed or can form in or on the product, e.g. if the product was moved from a cold to a warm environment.
25. Do not close any slots or openings on the product, since they are necessary for ventilation and prevent the product from overheating. Do not place the product on soft surfaces such as sofas or rugs or inside a closed housing, unless this is well ventilated.
26. Do not place the product on heat-generating devices such as radiators or fan heaters. The temperature of the environment must not exceed the maximum temperature specified in the data sheet.
27. Batteries and storage batteries must not be exposed to high temperatures or fire. Keep batteries and storage batteries away from children. Do not short-circuit batteries and storage batteries.
If batteries or storage batteries are improperly replaced, this can cause an explosion (warning: lithium cells). Replace the battery or storage battery only with the matching Rohde & Schwarz type (see spare parts list). Batteries and storage batteries must be recycled and kept separate from residual waste. Batteries and storage batteries that contain lead, mercury or cadmium are hazardous waste. Observe the national regulations regarding waste disposal and recycling.
28. Please be aware that in the event of a fire, toxic substances (gases, liquids etc.) that may be hazardous to your health may escape from the product.
29. The product can be very heavy. Be careful when moving it to avoid back or other physical injuries.
30. Do not place the product on surfaces, vehicles, cabinets or tables that for reasons of weight or stability are unsuitable for this purpose. Always follow the manufacturer's installation instructions when installing the product and fastening it to objects or structures (e.g. walls and shelves).
31. Handles on the products are designed exclusively for personnel to hold or carry the product. It is therefore not permissible to use handles for fastening the product to or on means of transport such as cranes, fork lifts, wagons, etc. The user is responsible for securely fastening the products to or on the means of transport and for observing the safety regulations of the manufacturer of the means of transport. Noncompliance can result in personal injury or material damage.
32. If you use the product in a vehicle, it is the sole responsibility of the driver to drive the vehicle safely. Adequately secure the product in the vehicle to prevent injuries or other damage in the event of an accident. Never use the product in a moving vehicle if doing so could distract the driver of the vehicle. The driver is always responsible for the safety of the vehicle. The manufacturer assumes no responsibility for accidents or collisions.
33. If a laser product (e.g. a CD/DVD drive) is integrated in a Rohde & Schwarz product, do not use any other settings or functions than those described in the product documentation. Otherwise this may be hazardous to your health, since the laser beam can cause irreversible damage to your eyes. Never try to take such products apart, and never look into the laser beam.
34. Prior to cleaning, disconnect the product from the AC supply. Use a soft, non-linting cloth to clean the product. Never use chemical cleaning agents such as alcohol, acetone or diluent for cellulose lacquers.

Informaciones elementales de seguridad



¡Es imprescindible leer y observar las siguientes instrucciones e informaciones de seguridad!







El principio del grupo de empresas Rohde & Schwarz consiste en tener nuestros productos siempre al día con los estándares de seguridad y de ofrecer a nuestros clientes el máximo grado de seguridad. Nuestros productos y todos los equipos adicionales son siempre fabricados y examinados según las normas de seguridad vigentes. Nuestra sección de gestión de la seguridad de calidad controla constantemente que sean cumplidas estas normas. El presente producto ha sido fabricado y examinado según el comprobante de conformidad adjunto según las normas de la CE y ha salido de nuestra planta en estado impecable según los estándares técnicos de seguridad. Para poder preservar este estado y garantizar un funcionamiento libre de peligros, el usuario deberá atenerse a todas las indicaciones, informaciones de seguridad y notas de alerta. El grupo de empresas Rohde & Schwarz está siempre a su disposición en caso de que tengan preguntas referentes a estas informaciones de seguridad.

Además queda en la responsabilidad del usuario utilizar el producto en la forma debida. Este producto está destinado exclusivamente al uso en la industria y el laboratorio o, si ha sido expresamente autorizado, para aplicaciones de campo y de ninguna manera deberá ser utilizado de modo que alguna persona/cosa pueda sufrir daño. El uso del producto fuera de sus fines definidos o despreciando las informaciones de seguridad del fabricante queda en la responsabilidad del usuario. El fabricante no se hace en ninguna forma responsable de consecuencias a causa del mal uso del producto.

Se parte del uso correcto del producto para los fines definidos si el producto es utilizado dentro de las instrucciones de la correspondiente documentación de producto y dentro del margen de rendimiento definido (ver hoja de datos, documentación, informaciones de seguridad que siguen). El uso del producto hace necesarios conocimientos profundos y conocimientos básicas del idioma inglés. Por eso se debe tener en cuenta que el producto sólo pueda ser operado por personal especializado o personas minuciosamente instruidas con las capacidades correspondientes. Si fuera necesaria indumentaria de seguridad para el uso de productos de R&S, encontrará la información debida en la documentación del producto en el capítulo correspondiente. Guarde bien las informaciones de seguridad elementales, así como la documentación del producto y entréguela a usuarios posteriores.

Símbolos y definiciones de seguridad

							
Ver documentación de producto	Informaciones para maquinaria con un peso de > 18kg	Peligro de golpe de corriente	¡Advertencia! Superficie caliente	Conexión a conductor protector	Conexión a tierra	Conexión a masa conductora	¡Cuidado! Elementos de construcción con peligro de carga electrostática

					
Potencia EN MARCHA/PARADA	Indicación Stand-by	Corriente continua DC	Corriente alterna AC	Corriente continua/- alterna DC/AC	El aparato está protegido en su totalidad por un aislamiento de doble refuerzo

Informaciones elementales de seguridad

Tener en cuenta las informaciones de seguridad sirve para tratar de evitar daños y peligros de toda clase. Es necesario de que se lean las siguientes informaciones de seguridad concienzudamente y se tengan en cuenta debidamente antes de la puesta en funcionamiento del producto. También deberán ser tenidas en cuenta las informaciones para la protección de personas que encontrarán en el capítulo correspondiente de la documentación de producto y que también son obligatorias de seguir. En las informaciones de seguridad actuales hemos juntado todos los objetos vendidos por el grupo de empresas Rohde & Schwarz bajo la denominación de „producto“, entre ellos también aparatos, instalaciones así como toda clase de accesorios.

Palabras de señal y su significado

PELIGRO	Identifica un peligro directo con riesgo elevado de provocar muerte o lesiones de gravedad si no se toman las medidas oportunas.
ADVERTENCIA	Identifica un posible peligro con riesgo medio de provocar muerte o lesiones (de gravedad) si no se toman las medidas oportunas.
ATENCIÓN	Identifica un peligro con riesgo reducido de provocar lesiones de gravedad media o leve si no se toman las medidas oportunas.
AVISO	Indica la posibilidad de utilizar mal el producto y a consecuencia dañarlo. En la documentación del producto se emplea de forma sinónima el término CUIDADO.

Las palabras de señal corresponden a la definición habitual para aplicaciones civiles en el área económica europea. Pueden existir definiciones diferentes a esta definición en otras áreas económicas o en aplicaciones militares. Por eso se deberá tener en cuenta que las palabras de señal aquí descritas sean utilizadas siempre solamente en combinación con la correspondiente documentación de producto y solamente en combinación con el producto correspondiente. La utilización de las palabras de señal en combinación con productos o documentaciones que no les correspondan puede llevar a malinterpretaciones y tener por consecuencia daños en personas u objetos.

Informaciones de seguridad elementales

- El producto solamente debe ser utilizado según lo indicado por el fabricante referente a la situación y posición de funcionamiento sin que se obstruya la ventilación. Si no se convino de otra manera, es para los productos R&S válido lo que sigue:
como posición de funcionamiento se define por principio la posición con el suelo de la caja para abajo, modo de protección IP 2X, grado de suciedad 2, categoría de sobrecarga eléctrica 2, utilizar solamente en estancias interiores, utilización hasta 2000 m sobre el nivel del mar, transporte hasta 4.500 m sobre el nivel del mar.
Se aplicará una tolerancia de $\pm 10\%$ sobre el voltaje nominal y de $\pm 5\%$ sobre la frecuencia nominal.
- En todos los trabajos deberán ser tenidas en cuenta las normas locales de seguridad de trabajo y de prevención de accidentes. El producto solamente debe de ser abierto por personal especializado autorizado. Antes de efectuar trabajos en el producto o abrirlo deberá este ser desconectado de la corriente. El ajuste, el cambio de partes, la manutención y la reparación deberán ser solamente efectuadas por electricistas autorizados por R&S. Si se reponen partes con importancia para los aspectos de seguridad (por ejemplo el enchufe, los transformadores o los fusibles), solamente podrán ser sustituidos por partes originales. Después de cada recambio de partes elementales para la seguridad deberá ser efectuado un control de seguridad (control a primera vista, control de conductor protector, medición de resistencia de aislamiento, medición de la corriente conductora, control de funcionamiento).

Informaciones elementales de seguridad

3. Como en todo producto de fabricación industrial no puede ser excluido en general de que se produzcan al usarlo elementos que puedan generar alergias, los llamados elementos alergénicos (por ejemplo el níquel). Si se produjeran en el trato con productos R&S reacciones alérgicas, como por ejemplo urticaria, estornudos frecuentes, irritación de la conjuntiva o dificultades al respirar, se deberá consultar inmediatamente a un médico para averiguar los motivos de estas reacciones.
 4. Si productos / elementos de construcción son tratados fuera del funcionamiento definido de forma mecánica o térmica, pueden generarse elementos peligrosos (polvos de sustancia de metales pesados como por ejemplo plomo, berilio, níquel). La partición elemental del producto, como por ejemplo sucede en el tratamiento de materias residuales, debe de ser efectuada solamente por personal especializado para estos tratamientos. La partición elemental efectuada inadecuadamente puede generar daños para la salud. Se deben tener en cuenta las directivas nacionales referentes al tratamiento de materias residuales.
 5. En el caso de que se produjeran agentes de peligro o combustibles en la aplicación del producto que debieran de ser transferidos a un tratamiento de materias residuales, como por ejemplo agentes refrigerantes que deben ser repuestos en periodos definidos, o aceites para motores, deberán ser tenidas en cuenta las prescripciones de seguridad del fabricante de estos agentes de peligro o combustibles y las regulaciones regionales para el tratamiento de materias residuales. Cuiden también de tener en cuenta en caso dado las prescripciones de seguridad especiales en la descripción del producto.
 6. Ciertos productos, como por ejemplo las instalaciones de radiocomunicación RF, pueden a causa de su función natural, emitir una radiación electromagnética aumentada. En vista a la protección de la vida en desarrollo deberían ser protegidas personas embarazadas debidamente. También las personas con un bypass pueden correr peligro a causa de la radiación electromagnética.
- El empresario/usuario está comprometido a valorar y señalar áreas de trabajo en las que se corra un riesgo aumentado de exposición a radiaciones para evitar riesgos.
7. La utilización de los productos requiere instrucciones especiales y una alta concentración en el manejo. Debe de ponerse por seguro de que las personas que manejen los productos estén a la altura de los requerimientos necesarios referente a sus aptitudes físicas, psíquicas y emocionales, ya que de otra manera no se pueden excluir lesiones o daños de objetos. El empresario lleva la responsabilidad de seleccionar el personal usuario apto para el manejo de los productos.
 8. Antes de la puesta en marcha del producto se deberá tener por seguro de que la tensión preseleccionada en el producto equivalga a la del la red de distribución. Si es necesario cambiar la preselección de la tensión también se deberán en caso dabo cambiar los fusibles correspondientes del producto.
 9. Productos de la clase de seguridad I con alimentación móvil y enchufe individual de producto solamente deberán ser conectados para el funcionamiento a tomas de corriente de contacto de seguridad y con conductor protector conectado.
 10. Queda prohibida toda clase de interrupción intencionada del conductor protector, tanto en la toma de corriente como en el mismo producto. Puede tener como consecuencia el peligro de golpe de corriente por el producto. Si se utilizaran cables o enchufes de extensión se deberá poner al seguro que es controlado su estado técnico de seguridad.
 11. Si el producto no está equipado con un interruptor para desconectarlo de la red, se deberá considerar el enchufe del cable de distribución como interruptor. En estos casos deberá asegurar de que el enchufe sea de fácil acceso y nabejo (según la medida del cable de distribución, aproximadamente 2 m). Los interruptores de función o electrónicos no son aptos para el corte de la red eléctrica. Si los productos sin interruptor están integrados en bastidores o instalaciones, se deberá instalar el interruptor al nivel de la instalación.

Informaciones elementales de seguridad

12. No utilice nunca el producto si está dañado el cable eléctrico. Compruebe regularmente el correcto estado de los cables de conexión a red. Asegure a través de las medidas de protección y de instalación adecuadas de que el cable de eléctrico no pueda ser dañado o de que nadie pueda ser dañado por él, por ejemplo al tropezar o por un golpe de corriente.
13. Solamente está permitido el funcionamiento en redes de distribución TN/TT aseguradas con fusibles de como máximo 16 A (utilización de fusibles de mayor amperaje sólo previa consulta con el grupo de empresas Rohde & Schwarz).
14. Nunca conecte el enchufe en tomas de corriente sucias o llenas de polvo. Introduzca el enchufe por completo y fuertemente en la toma de corriente. Si no tiene en consideración estas indicaciones se arriesga a que se originen chispas, fuego y/o heridas.
15. No sobrecargue las tomas de corriente, los cables de extensión o los enchufes de extensión ya que esto pudiera causar fuego o golpes de corriente.
16. En las mediciones en circuitos de corriente con una tensión de entrada de $U_{\text{eff}} > 30 \text{ V}$ se deberá tomar las precauciones debidas para impedir cualquier peligro (por ejemplo medios de medición adecuados, seguros, limitación de tensión, corte protector, aislamiento etc.).
17. En caso de conexión con aparatos de la técnica informática se deberá tener en cuenta que estos cumplan los requisitos del estándar IEC950/EN60950.
18. A menos que esté permitido expresamente, no retire nunca la tapa ni componentes de la carcasa mientras el producto esté en servicio. Esto pone a descubierto los cables y componentes eléctricos y puede causar heridas, fuego o daños en el producto.
19. Si un producto es instalado fijamente en un lugar, se deberá primero conectar el conductor protector fijo con el conductor protector del aparato antes de hacer cualquier otra conexión. La instalación y la conexión deberán ser efectuadas por un electricista especializado.
20. En caso de que los productos que son instalados fijamente en un lugar sean sin protector implementado, autointerruptor o similares objetos de protección, el circuito de suministro de corriente deberá estar protegido de manera que usuarios y productos estén suficientemente protegidos.
21. Por favor, no introduzca ningún objeto que no esté destinado a ello en los orificios de la caja del aparato. No vierta nunca ninguna clase de líquidos sobre o en la caja. Esto puede producir cortocircuitos en el producto y/o puede causar golpes de corriente, fuego o heridas.
22. Asegúrese con la protección adecuada de que no pueda originarse en el producto una sobrecarga por ejemplo a causa de una tormenta. Si no se verá el personal que lo utilice expuesto al peligro de un golpe de corriente.
23. Los productos R&S no están protegidos contra líquidos si no es que exista otra indicación, ver también punto 1. Si no se tiene en cuenta esto se arriesga el peligro de golpe de corriente para el usuario o de daños en el producto lo cual también puede llevar al peligro de personas.
24. No utilice el producto bajo condiciones en las que pueda producirse y se hayan producido líquidos de condensación en o dentro del producto como por ejemplo cuando se desplaza el producto de un lugar frío a un lugar caliente.
25. Por favor no cierre ninguna ranura u orificio del producto, ya que estas son necesarias para la ventilación e impiden que el producto se caliente demasiado. No pongan el producto encima de materiales blandos como por ejemplo sofás o alfombras o dentro de una caja cerrada, si esta no está suficientemente ventilada.
26. No ponga el producto sobre aparatos que produzcan calor, como por ejemplo radiadores o calentadores. La temperatura ambiental no debe superar la temperatura máxima especificada en la hoja de datos.

Informaciones elementales de seguridad

27. Baterías y acumuladores no deben de ser expuestos a temperaturas altas o al fuego. Guardar baterías y acumuladores fuera del alcance de los niños. No cortocircuitar baterías ni acumuladores. Si las baterías o los acumuladores no son cambiados con la debida atención existirá peligro de explosión (atención células de litio). Cambiar las baterías o los acumuladores solamente por los del tipo R&S correspondiente (ver lista de piezas de recambio). Las baterías y acumuladores deben reutilizarse y no deben acceder a los vertederos. Las baterías y acumuladores que contienen plomo, mercurio o cadmio deben tratarse como residuos especiales. Respete en esta relación las normas nacionales de evacuación y reciclaje.
28. Por favor tengan en cuenta que en caso de un incendio pueden desprenderse del producto agentes venenosos (gases, líquidos etc.) que pueden generar daños a la salud.
29. El producto puede poseer un peso elevado. Muévelo con cuidado para evitar lesiones en la espalda u otras partes corporales.
30. No sitúe el producto encima de superficies, vehículos, estantes o mesas, que por sus características de peso o de estabilidad no sean aptas para él. Siga siempre las instrucciones de instalación del fabricante cuando instale y asegure el producto en objetos o estructuras (por ejemplo paredes y estantes).
31. Las asas instaladas en los productos sirven solamente de ayuda para el manejo que solamente está previsto para personas. Por eso no está permitido utilizar las asas para la sujeción en o sobre medios de transporte como por ejemplo grúas, carretillas elevadoras de horquilla, carros etc. El usuario es responsable de que los productos sean sujetados de forma segura a los medios de transporte y de que las prescripciones de seguridad del fabricante de los medios de transporte sean observadas. En caso de que no se tengan en cuenta pueden causarse daños en personas y objetos.
32. Si llega a utilizar el producto dentro de un vehículo, queda en la responsabilidad absoluta del conductor que conducir el vehículo de manera segura. Asegure el producto dentro del vehículo debidamente para evitar en caso de un accidente las lesiones u otra clase de daños. No utilice nunca el producto dentro de un vehículo en movimiento si esto pudiera distraer al conductor. Siempre queda en la responsabilidad absoluta del conductor la seguridad del vehículo. El fabricante no asumirá ninguna clase de responsabilidad por accidentes o colisiones.
33. Dado el caso de que esté integrado un producto de láser en un producto R&S (por ejemplo CD/DVD-ROM) no utilice otras instalaciones o funciones que las descritas en la documentación de producto. De otra manera pondrá en peligro su salud, ya que el rayo láser puede dañar irreversiblemente sus ojos. Nunca trate de descomponer estos productos. Nunca mire dentro del rayo láser.
34. Antes de proceder a la limpieza, desconecte el producto de la red. Realice la limpieza con un paño suave, que no se deshilache. No utilice de ninguna manera agentes limpiadores químicos como, por ejemplo, alcohol, acetona o nitrodiluyente.

Certified Quality System

DIN EN ISO 9001 : 2000

DIN EN 9100 : 2003

DIN EN ISO 14001 : 2004

DQS REG. NO 001954 QM UM

QUALITÄTSZERTIFIKAT

Sehr geehrter Kunde,

Sie haben sich für den Kauf eines Rohde & Schwarz-Produktes entschieden. Hiermit erhalten Sie ein nach modernsten Fertigungsmethoden hergestelltes Produkt. Es wurde nach den Regeln unseres Managementsystems entwickelt, gefertigt und geprüft.

Das Rohde & Schwarz Managementsystem ist zertifiziert nach:

DIN EN ISO 9001:2000
DIN EN 9100:2003
DIN EN ISO 14001:2004

CERTIFICATE OF QUALITY

Dear Customer,

you have decided to buy a Rohde & Schwarz product. You are thus assured of receiving a product that is manufactured using the most modern methods available. This product was developed, manufactured and tested in compliance with our quality management system standards.

The Rohde & Schwarz quality management system is certified according to:

DIN EN ISO 9001:2000
DIN EN 9100:2003
DIN EN ISO 14001:2004

CERTIFICAT DE QUALITÉ

Cher Client,

vous avez choisi d'acheter un produit Rohde & Schwarz. Vous disposez donc d'un produit fabriqué d'après les méthodes les plus avancées. Le développement, la fabrication et les tests respectent nos normes de gestion qualité.

Le système de gestion qualité de Rohde & Schwarz a été homologué conformément aux normes:

DIN EN ISO 9001:2000
DIN EN 9100:2003
DIN EN ISO 14001:2004



ROHDE & SCHWARZ

Customer Support

Technical support – where and when you need it

For quick, expert help with any Rohde & Schwarz equipment, contact one of our Customer Support Centers. A team of highly qualified engineers provides telephone support and will work with you to find a solution to your query on any aspect of the operation, programming or applications of Rohde & Schwarz equipment.

Up-to-date information and upgrades

To keep your instrument up-to-date and to be informed about new application notes related to your instrument, please send an e-mail to the Customer Support Center stating your instrument and your wish.

We will take care that you will get the right information.

USA & Canada

Monday to Friday (except US public holidays)

8:00 AM – 8:00 PM Eastern Standard Time (EST)

Tel. from USA 888-test-rsa (888-837-8772) (opt 2)

From outside USA +1 410 910 7800 (opt 2)

Fax +1 410 910 7801

E-mail CustomerSupport@rohde-schwarz.com

East Asia

Monday to Friday (except Singaporean public holidays)

8:30 AM – 6:00 PM Singapore Time (SGT)

Tel. +65 6 513 0488

Fax +65 6 846 1090

E-mail CustomerSupport@rohde-schwarz.com

Rest of the World

Monday to Friday (except German public holidays)

08:00 – 17:00 Central European Time (CET)

Tel. from Europe +49 (0) 180 512 42 42*

From outside Europe +49 89 4129 13776

Fax +49 (0) 89 41 29 637 78

E-mail CustomerSupport@rohde-schwarz.com

* 0.14 €/Min within the German fixed-line telephone network, varying prices for the mobile telephone network and in different countries.



Address List

Headquarters, Plants and Subsidiaries

Headquarters

ROHDE & SCHWARZ GmbH & Co. KG
Mühlendorfstraße 15 · D-81671 München
P.O.Box 80 14 69 · D-81614 München

Phone +49 (89) 41 29-0
Fax +49 (89) 41 29-121 64
info.rs@rohde-schwarz.com

Plants

ROHDE & SCHWARZ Messgerätebau GmbH
Riedbachstraße 58 · D-87700 Memmingen
P.O.Box 16 52 · D-87686 Memmingen

Phone +49 (83 31) 1 08-0
+49 (83 31) 1 08-1124
info.rsmb@rohde-schwarz.com

ROHDE & SCHWARZ GmbH & Co. KG
Werk Teisnach
Kaikenrieder Straße 27 · D-94244 Teisnach
P.O.Box 11 49 · D-94240 Teisnach

Phone +49 (99 23) 8 50-0
Fax +49 (99 23) 8 50-174
info.rsds@rohde-schwarz.com

ROHDE & SCHWARZ závod
Vimperk, s.r.o.
Location Spidrova 49
CZ-38501 Vimperk

Phone +420 (388) 45 21 09
Fax +420 (388) 45 21 13

ROHDE & SCHWARZ GmbH & Co. KG
Dienstleistungszentrum Köln
Graf-Zeppelin-Straße 18 · D-51147 Köln
P.O.Box 98 02 60 · D-51130 Köln

Phone +49 (22 03) 49-0
Fax +49 (22 03) 49 51-229
info.rsdc@rohde-schwarz.com
service.rsdc@rohde-schwarz.com

Subsidiaries

R&S BICK Mobilfunk GmbH
Fritz-Hahne-Str. 7 · D-31848 Bad Münder
P.O.Box 20 02 · D-31844 Bad Münder

Phone +49 (50 42) 9 98-0
Fax +49 (50 42) 9 98-105
info.bick@rohde-schwarz.com

ROHDE & SCHWARZ FTK GmbH
Wendenschloßstraße 168, Haus 28
D-12557 Berlin

Phone +49 (30) 658 91-122
Fax +49 (30) 655 50-221
info.ftk@rohde-schwarz.com

ROHDE & SCHWARZ SIT GmbH
Am Studio 3
D-12489 Berlin

Phone +49 (30) 658 84-0
Fax +49 (30) 658 84-183
info.sit@rohde-schwarz.com

R&S Systems GmbH
Graf-Zeppelin-Straße 18
D-51147 Köln

Phone +49 (22 03) 49-5 23 25
Fax +49 (22 03) 49-5 23 36
info.rssys@rohde-schwarz.com

GEDIS GmbH
Sophienblatt 100
D-24114 Kiel

Phone +49 (431) 600 51-0
Fax +49 (431) 600 51-11
sales@gedis-online.de

HAMEG Instruments GmbH
Industriestraße 6
D-63533 Mainhausen

Phone +49 (61 82) 800-0
Fax +49 (61 82) 800-100
info@hameg.de

Locations Worldwide

Please refer to our homepage: www.rohde-schwarz.com

- ◆ Sales Locations
- ◆ Service Locations
- ◆ National Websites

Contents

1 General Information	1.1
Introduction to R&S FS-K30 & Noise Measurements	1.2
Installation.....	1.2
Starting the application	1.4
Exiting the application	1.4
Quick Start Guide	1.5
Setting up the measurement	1.5
Performing the amplifier measurement.....	1.8
Navigation	1.9
Hotkeys	1.9
Softkeys.....	1.11
Hardkeys	1.13
External Keyboard.....	1.14
Mouse.....	1.15
Selecting & Editing Parameters	1.15
Status Bar & Title Bar.....	1.23
Save/Recall.....	1.24
Printing	1.25
Limit Line.....	1.26
Adding Limit Lines.....	1.27
Modifying Limit Lines.....	1.29
Deleting Limit Lines.....	1.30
Enabling / disabling Limit Lines.....	1.30
Trace Menu.....	1.31
Marker Menu	1.33
Adjusting Markers	1.33
Toggle Marker Display	1.34
Assigning Markers to Traces.....	1.34
MKR-> Menu.....	1.35

2 Measurements & Settings	2.1
Measurement modes & schematics	2.1
Direct measurements	2.2
Frequency-converting measurements	2.3
Calibration	2.4
Running measurements	2.5
Measurement results	2.6
Frequency List measurements	2.6
Fixed Frequency measurements	2.9
Frequency Settings	2.10
Frequency Settings	2.11
Frequency Table	2.13
Schematic Diagrams	2.14
Measurement Settings	2.15
Calibration	2.16
Analyzer Settings	2.17
Generator Settings	2.20
Generator Frequency	2.22
ENR Settings	2.23
ENR Settings	2.24
ENR Table	2.25
Loss Settings	2.27
Loss Settings – Loss Input Settings	2.28
Loss Input Table	2.29
Loss Settings – Loss Output Settings	2.30
Loss Output Table	2.31
Graphic Settings	2.33
Results Settings	2.33
Noise Trace Settings	2.35
Gain Trace Settings	2.36
Noise and Gain X-Axis Settings	2.37
Measurements in Detail	2.38
DUTs with Very Large Gain	2.38
Frequency-converting Measurement	2.39

3 Remote Control	3.1
Description of commands	3.1
Notation	3.1
ABORt Subsystem	3.3
CALCulate: Subsystem	3.4
DISPlay Subsystem	3.14
FETCh Subsystem	3.17
FORMAT Subsystem	3.19
INITiate Subsystem	3.20
INPut Subsystem	3.21
INSTrument Subsystem	3.22
SENSe Subsystem	3.23
SOURce Subsystem	3.33
STATus Subsystem	3.35
SYSTem Subsystem	3.39
Status reporting registers	3.42
Description of the Status Registers	3.44
Error Reporting	3.45
4 List of Warnings & Error Messages	4.1
5 Index	5.1

1 General Information

The Rohde & Schwarz R&S FS-K30 application extends the functionality of the R&S FSP and R&S FSU spectrum analyzers to enable noise figure measurements.

This manual supports the user in working with R&S FS-K30. It aids the preparation, execution and evaluation of a measurement and gives many helpful hints and examples.

For the user wanting to make a quick start to using R&S FS-K30, the Quick Start Guide section below works step-by-step through an ordinary noise figure measurement. The remainder of this section describes all of the basic information about how the R&S FS-K30 application works, without covering noise measurements in detail. A detailed description of all measurement modes, settings and results can be found in section 2. Section 3 covers remote control operation of R&S FS-K30.

This section covers the following subjects:

- Introduction to R&S FS-K30 & noise measurements
- Installation
- Starting the application
- Quick start guide – allows the user to get up-and-running in minimum time
- Navigation
- Save/recall – saving & recalling user settings & measurement results
- Printing
- Limit lines
- Markers
- Exiting the application
- Getting started – example measurements

Introduction to R&S FS-K30 & Noise Measurements

The use of an R&S FSP/R&S FSU/R&S FSQ spectrum analyzer with its high sensitivity and level accuracy enables the accurate and reproducible measurement of the noise figure of a Device Under Test, for example, of low-noise FET amplifier circuits with noise figures of less than 1 dB. Compared with specialist noise-measurement instruments, the properties of the analyzer are ideal for noise measurements:

- Different configurations of the sweep number and sweep time for the level measurement also allows the noise figure (and even the gain) of the DUT to be determined even at low frequencies.
- The high dynamic range of the analyzer enables measurements on highly amplifying DUTs.
- The frequency range of the analyzer can be fully utilised as a measurement range.

R&S FS-K30 makes full use of the features and accuracy of the spectrum analyzer to provide accurate and flexible noise measurements that are very easy to use.

Installation

- From the analyzer select firmware update. Press the **SETUP** hardkey followed by **NEXT**, **FIRMWARE UPDATE** and finally the **FIRMWARE UPDATE** softkey. Following the instructions displayed.

Once the installation has completed the analyzer will reboot.

Once the option has been installed it needs to be activated:

- Start up the analyzer
- Press the **SETUP** hardkey, followed by the **GENERAL SETUP** softkey and then the **OPTIONS** softkey. A list of the options currently activated is displayed.
- Press the **INSTALL OPTION** softkey. A Dialog is displayed allowing the option key to be entered.

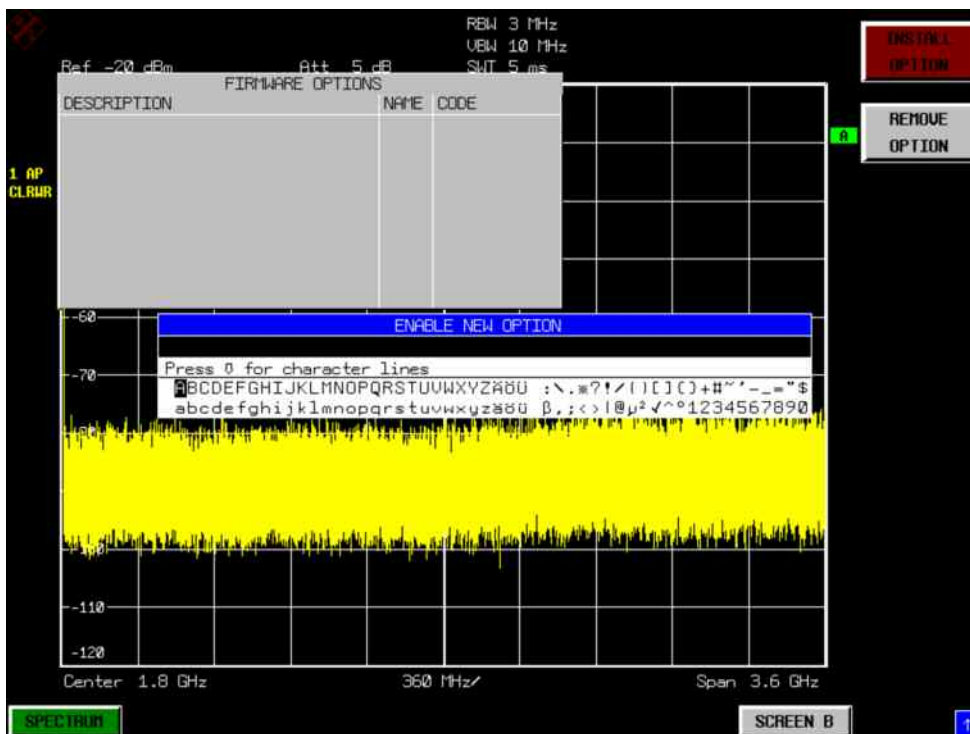

- Enter the option key supplied with the R&S FS-K30 software.
- When a valid option key has been supplied a dialog will be displayed explaining that a reboot is required to complete this operation. Select OK in this dialog and the instrument will be rebooted
- When the analyzer starts after the reboot a new hotkey will be displayed at the bottom of the display labelled *NOISE*. In addition an entry for the R&S FS-K30 option will be displayed in the *FIRMWARE OPTIONS* dialog.

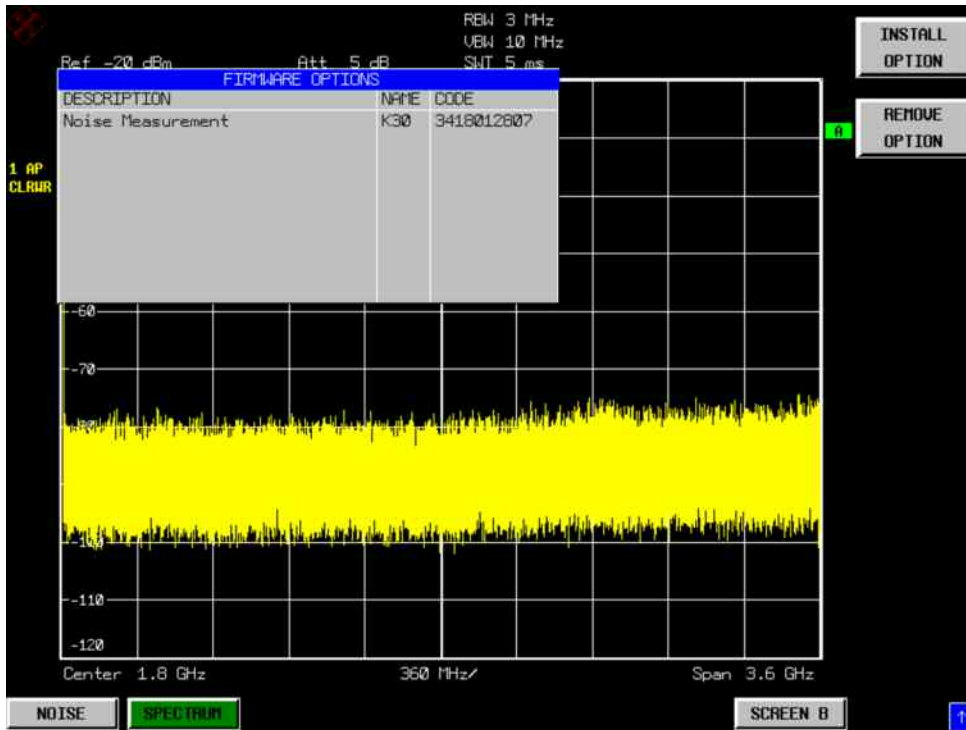

Starting the application

Power up the R&S FSP, R&S FSU or R&S FSQ spectrum analyzer. When R&S FS-K30 is correctly installed, there will be a hotkey labelled *NOISE* at the bottom of the screen. Press the *NOISE* hotkey to start R&S FS-K30.

Note that if the spectrum analyzer is powered down whilst R&S FS-K30 is active, then when the spectrum analyzer is powered up again it will start up in the R&S FS-K30 application. The application will start up with the same settings as those at the end of the last measurement.

Exiting the application

To exit the R&S FS-K30 option, press the *SPECTRUM* hotkey at the bottom of the screen. This will cause the option to exit and the spectrum analyzer to be activated with the same settings as were set when the R&S FS-K30 option was activated.

Quick Start Guide

This section helps the user to quickly become familiar with R&S FS-K30 by working step-by-step through an ordinary noise figure measurement. (Refer to section 2 for a detailed reference guide.)

The gain and noise figure of an amplifier are to be determined in the range from 220 MHz to 320 MHz.

Setting up the measurement

- Start the R&S FS-K30 application.
- Press the *SET FREQ* softkey to open the Frequency Settings view.

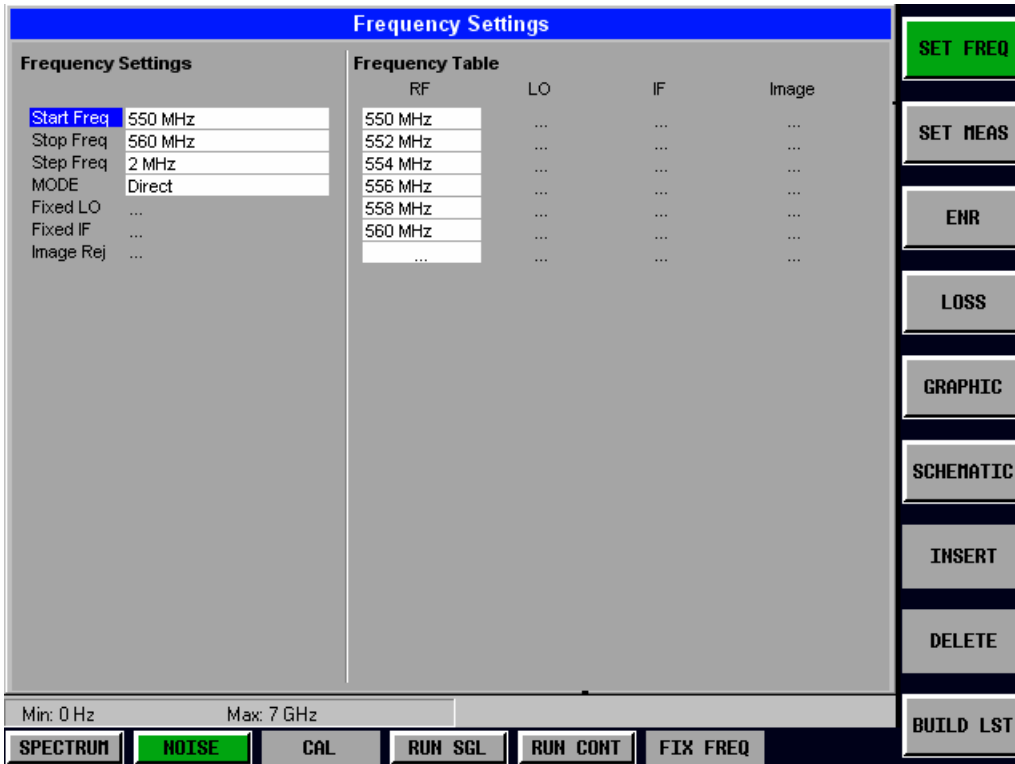

- Enter the desired frequency range in the Frequency Settings group of parameters. In our example, enter a *Start Frequency* of 220 MHz and a *Stop Frequency* of 320 MHz.

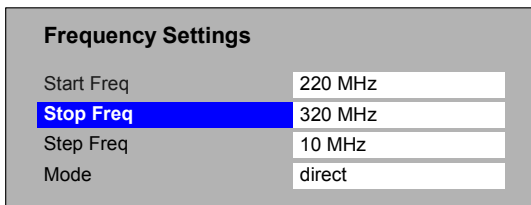

- Enter the desired *Step Frequency* size. In our example, 10 MHz should be entered. Thus, a measurement is taken at 11 frequency points: 220 MHz, 230 MHz, 240 MHz, ..., 320 MHz.

The number of steps can be increased to up to 100 frequency points. This would, of course, result in a correspondingly longer measurement time.

- Press the *ENR* softkey to open the ENR Settings view

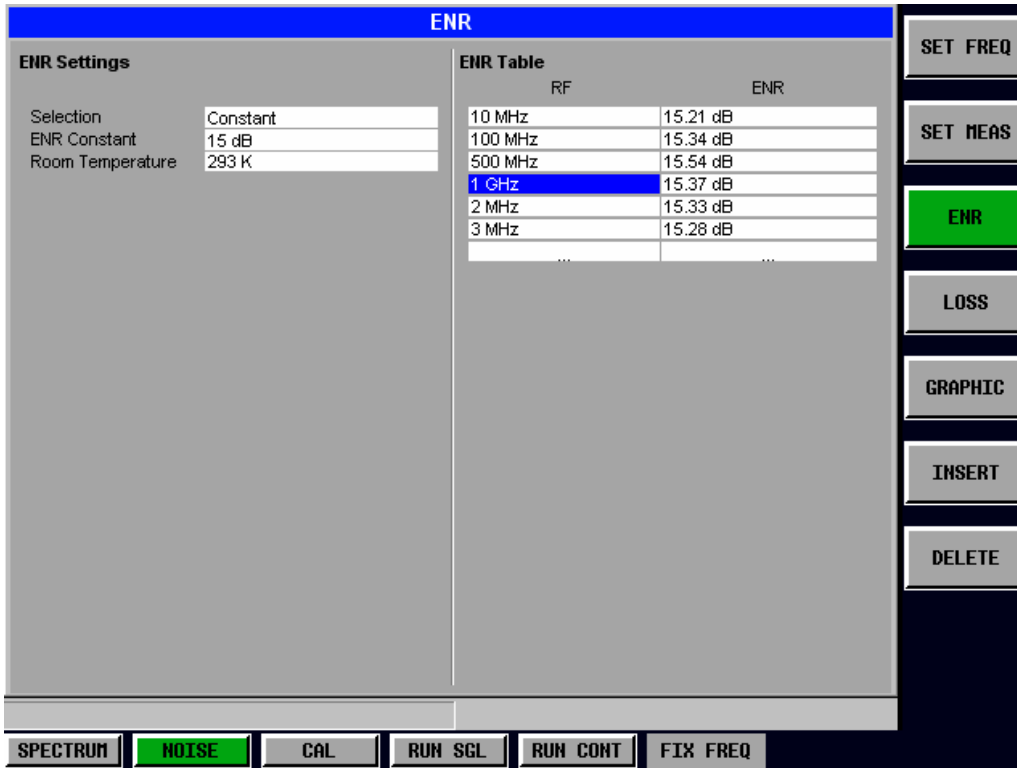

The default for the ENR value is 15 dB. The ENR value can either be entered as a constant value that is valid for all frequencies (*ENR Constant*) or as a list of frequency-dependent ENR values in the table on the right-hand-side of the ENR Settings view.

For a noise source with a frequency-dependent ENR, sampled ENR values must be entered for a number of different frequencies. The manufacturer of the noise source supplies these sampled values.

For the purposes of this introduction to R&S FS-K30, it is sufficient to specify a constant ENR value for this measurement. The default *Selection* for ENR is a Constant value for all frequencies, so this does not need to be changed.

Enter the ENR value that is valid for the measurement range of 220 MHz to 320 MHz in the *ENR Constant* field.

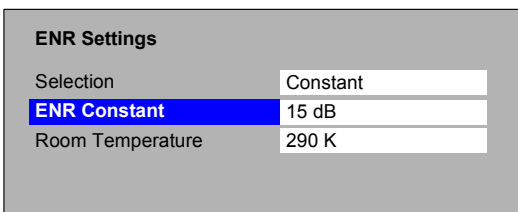

- Press the *SET MEAS* softkey to open the Measurement Settings view

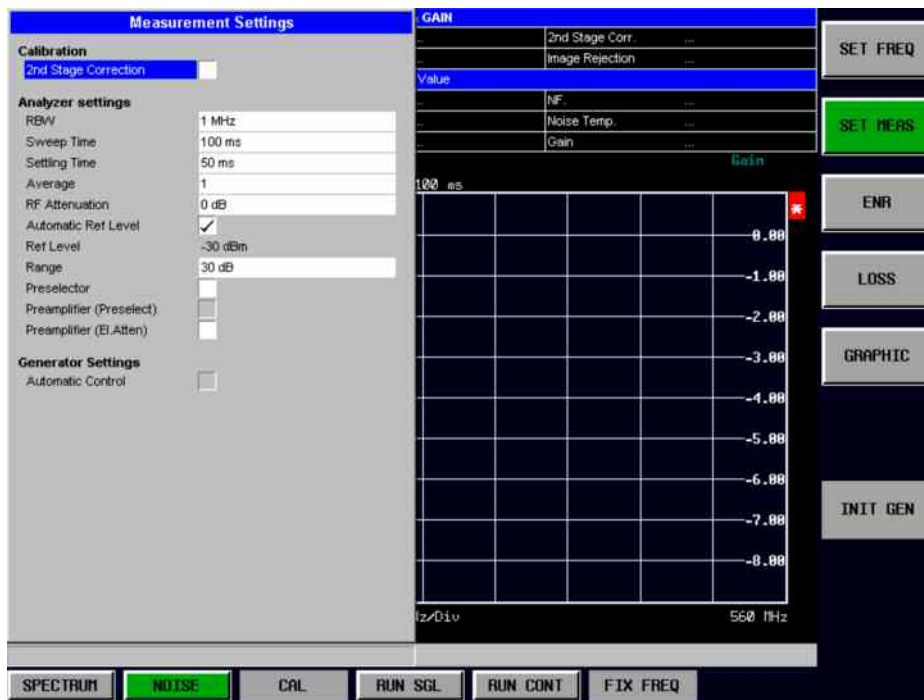

In order to perform measurements as accurately as possible the *Second Stage Correction* field needs to be set. This specifies that a separate calibration measurement is to be performed before the main measurement. The calibration measurement allows the noise characteristics of the analyzer to be measured and compensated for in the main measurement.

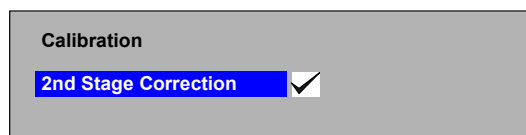

- Close the *SET MEAS* Settings view by pressing the *NOISE* hotkey.

Performing calibration

- Connect the noise source to the RF input of the spectrum analyzer. (see Fig. 1-1)
- Connect the supplied lowpass filter to the voltage supply input of the noise source.

Provide the voltage supply for the noise source by connecting it to the +28V socket of the analyzer (labelled NOISE SOURCE on the instrument) via a coax cable and the lowpass filter. The lowpass filter is connected between the noise source itself and the NOISE SOURCE socket of the analyzer as shown.

The purpose of the lowpass filter is to suppress any interference (e.g. due to RF interference), including interference from the supply line. This makes it possible to perform very precise measurements.

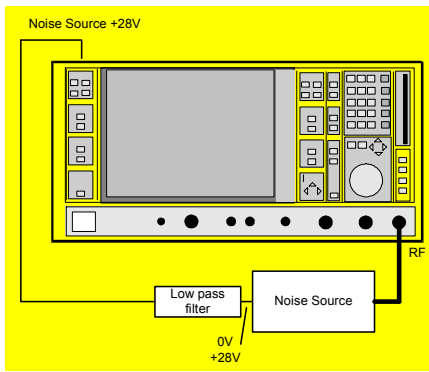

Fig. 1-1 Preparation for calibration

Set the *Second Stage Correction* parameter in the Measurement Setting view to ON. Calibration cannot be performed until this parameter is set.

Start the calibration of R&S FS-K30 by pressing the *CAL* hotkey.

During calibration, the text "*Running ...*" is displayed in the Status Bar at the bottom of the screen. The progress bar indicates the progress through the calibration measurement.

After successful calibration, the Status Bar will display "*Measurement Complete*" and the title bar at the top of the screen will show a *CALIBRATED* status on the right-hand-side.

Note that this calibration measurement calibrates only the R&S FS-K30 application and not the spectrum analyzer itself.

Performing the amplifier measurement

After calibration has been successfully completed, insert the DUT (in this example, the amplifier) into the test setup between the noise source and RF Input of the spectrum analyzer. (see Fig. 1-2)

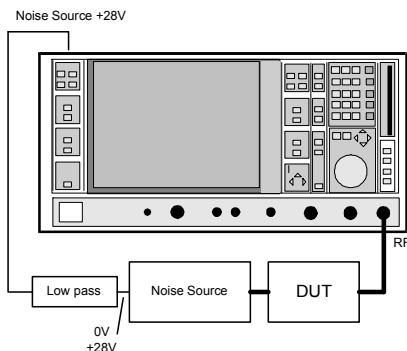

Fig. 1-2 Test Setup

➤ Start the measurement by pressing the *RUN SGL* hotkey.

During the measurement, the text "*Running...*" is displayed in the Status Bar at the bottom of the screen. The progress bar indicates the progress through the measurement.

Measurement results are updated as the measurement is in progress. The results are displayed in graphical form. There are two traces, one for Noise Figure/Temperature and one for the Gain of the DUT. The display can be toggled to a tabular list of measurement points by pressing the *DISPLAY* softkey

Navigation

This section deals with navigation within the option. Navigation here is taken to mean all forms of interaction with the option except for remote control. The different methods of interacting with the option are:

- Hotkeys
- Softkeys
- Hardkeys
- Numeric Keypad
- Roll-key
- Cursor Keys
- External Keyboard
- Mouse

Hotkeys

Hotkeys are allocated to the seven keys at the bottom edge of the screen. On initial start-up of the K30 option, the hotkeys provided are shown in Fig. 1-3. These hotkeys are present at all times once the option has been started.

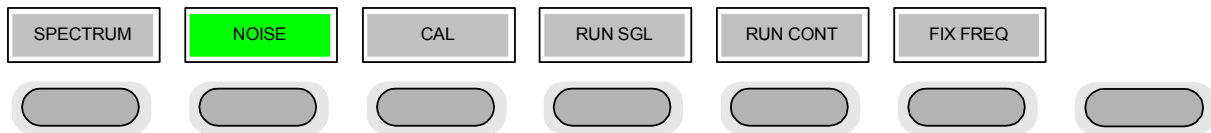
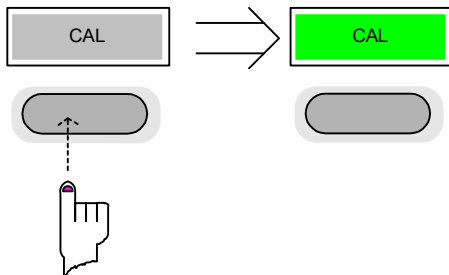
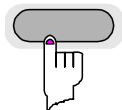

Fig. 1-3 Initial Hotkey menu

A keystroke activates the associated hotkey. An activated hotkey changes colour to green, as shown.



These hotkeys perform the following operations:



The *SPECTRUM* hotkey exits the R&S FS-K30 option & returns to the spectrum analyzer with all previous settings restored.

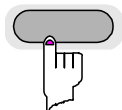
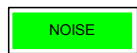

The *NOISE* hotkey returns the user to the home screen of K30, where measurement results can be seen. All settings views and dialogs are removed from the display, and the default softkey menu is displayed

The *NOISE* hotkey remains green whenever R&S FS-K30 is active

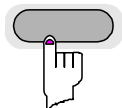
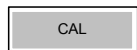

The *CAL* hotkey starts a calibration measurement.

If another measurement is running, such as frequency range or a fixed frequency measurement, the running measurement will be aborted before the calibration measurement is started.

Pressing the *CAL* hotkey whilst a calibration measurement is running causes the measurement to be stopped (aborted).

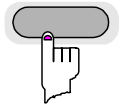
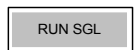

The *RUN SGL* hotkey starts a fixed frequency range measurement.

If another measurement is running, such as Calibration or a fixed frequency measurement, the running measurement will be aborted before the single frequency range measurement is started.

Pressing the *RUN SGL* hotkey whilst a single frequency range measurement is running causes the measurement to be stopped (aborted).

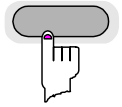
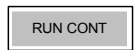

The *RUN CONT* hotkey starts a continuous frequency range measurement.

If another measurement is running, such as Calibration or a fixed frequency measurement, the running measurement will be aborted before the continuous frequency range measurement is started.

Pressing the *RUN CONT* hotkey whilst a continuous frequency range measurement is running causes the measurement to be stopped (aborted).

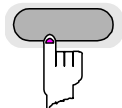

The *FIX FREQ* hotkey starts a fixed frequency measurement.

If another measurement is running, such as Calibration or a frequency range measurement, the running measurement will be aborted before the fixed frequency measurement is started.

Pressing the *FIX FREQ* hotkey whilst a fixed frequency measurement is running causes the measurement to be stopped (aborted).

The *FIX FREQ* hotkey is only available when results are displayed in tabular form and a valid result is selected in the table of results.

Softkeys

Settings Softkeys

The softkeys are assigned to the nine keys on the right-hand side of the display. These enable quick access to all of the parameter settings of the K30 option. Each of the top five softkeys, when pressed, brings up a settings view for a group of parameters. These softkeys are always available (except for when editing limit lines or trace memories and when using Save Recall / print manager) and are as follows:

SET FREQ	Frequency settings - measurement frequencies, measurement mode & schematic display
SET MEAS	Measurement settings - calibration, analyser & generator settings
ENR	ENR settings - constant & list
LOSS	Loss settings - Loss Input & Loss Output (constant & list)
GRAPHIC	Graphic settings - trace settings

Fig. 1-4 Main softkeys

Each of these groups of settings is described in detail in the Measurements & Settings section of this manual.

Other Softkeys

All other softkeys have different functions depending on the instrument state. Therefore, the labels (text) on the softkeys will vary to reflect their current function. The state of the softkeys is indicated by different appearances and colours, as follows:

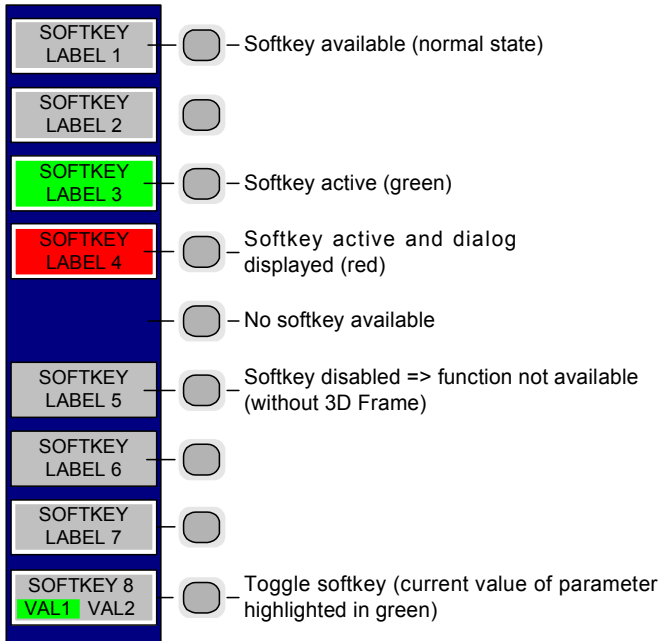

Fig. 1-5 Setup of the softkey area

A softkey in its normal state, where its function is available, is coloured grey with a 3D border.

A softkey that is disabled, because its function is not available, is coloured grey without a 3D border. Softkeys may become disabled because of the state of the instrument or because other settings disable the function associated with the softkey.

An active softkey (highlighted in green) is used when the softkey selects an item or view. For example, the *SCHEMATIC* softkey will be highlighted green when the schematic is displayed.

A toggle softkey is used to change the value of a parameter that has only two states. Each press of the softkey toggles the value of the parameter. The current parameter value is highlighted in green in the lower half of the softkey label. For example, in the measurement results view, the *DISPLAY* softkey will have either *LIST* or *GRAPH* highlighted in green depending on whether the results are currently displayed as a list of measurement points or graphical trace(s).

When no function is assigned to a softkey then no softkey label will be shown.

Hardkeys

Hardkeys allow quick access to the desired parameter and various functions. The hardkeys supported by the R&S FS-K30 option are as follows (other hardkeys do nothing):

FREQ Hardkey	When the <i>FREQ</i> hardkey is pressed the General Settings view is displayed (if it is not already being displayed) and the <i>Frequency</i> parameter is selected.
AMPT Hardkey	When the AMPT hardkey is pressed the General Settings view is displayed (if it is not already being displayed) and the relevant <i>Signal Level</i> parameter for the selected signal input is selected.
MKR Hardkey	When the MKR hardkey is pressed the main Marker softkey menu is displayed (if it is not already being displayed).
MKR-> Hardkey	When the MKR-> hardkey is pressed the Marker extension softkey menu is displayed (if it is not already being displayed).
SWEEP Hardkey	When the SWEEP hardkey is pressed the General Settings view is displayed (if it is not already being displayed) and the <i>Capture Time</i> parameter is selected.
MEAS Hardkey	When the MEAS hardkey is pressed the Main softkey menu is displayed (if it is not already being displayed).
TRACE Hardkey	When the TRACE hardkey is pressed the General Settings view is displayed (if it is not already being displayed) and the <i>Burst Count</i> parameter is selected.
DISP Hardkey	When the DISP hardkey is pressed the Display softkey menu is displayed (if it is not already being displayed).
FILE Hardkey	When the FILE hardkey is pressed, the Save & Recall softkey menu is displayed, allowing the save & recall of settings and/or measurement results of the K90 option.
PRESET Hardkey	When the PRESET hardkey is pressed the K90 option is exited and a preset will be performed. Note that all options (including R&S FSP-K90) shall also be preset.
HCOPY Hardkey	When the HCOPY hardkey is pressed the print manager softkey menu is displayed, allowing selection of the items to be printed.

External Keyboard

The external keyboard is optional. The keys on the external keyboard that can be used to interact with the K30 option are as follows:

Number keys 0 to 9

Decimal point (“.”) Inserts a decimal point “.” at the cursor position.

Minus key (“-“) Changes the sign of the mantissa or exponent of a numeric parameter. A “-“ is inserted at the cursor position in the case of an alphanumeric parameter.

ESC key Aborts the entry before it has been terminated. The previous value is restored.
Closes the entry field after termination of input.
Closes pop-up dialogs.

ENTER key Terminates the input of dimension quantities. The new value is set.
Invokes the input of parameters or immediately sets the new value.
Selects the highlighted item in drop-down menus.

Left and Right Cursor Keys are used to: Navigate between individual parameters within the setting views and some of the pop-up dialogs.
Navigate between the individual items within drop-down menus.
Move the cursor left & right inside the entry window to reach a particular position in the string during alphanumeric entry.

Up and Down Cursor keys are used to: Navigate between individual parameters within the setting views and some of the pop-up dialogs.
Navigate between the individual items within drop-down menus.
Increment or decrement the value of a parameter during numeric entry.

CTRL keys Used to activate hotkeys. Each of the seven hotkeys is allocated a different function (F) key. To access these hotkeys press CTRL and the corresponding F key together (see Fig. 1-6):

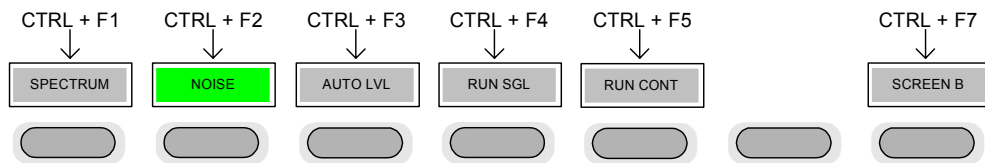

Fig. 1-6 Quick Access to Hotkeys

Function Keys Used to activate softkeys. Each of the nine softkeys is allocated a different function (F) key. To access these softkeys the corresponding F key, as shown below:

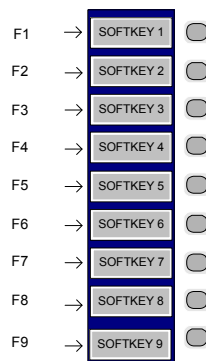

Fig. 1-7 Quick access to softkeys

Mouse

The mouse can be used to select individual parameters within the settings views or data entry dialogs and to activate hotkeys and softkeys. It can also be used to select values from a drop-down list.

Selecting & Editing Parameters

Parameters are set either by numeric or alphanumeric entry or by simple selection from a list of possible values (a drop-down list is used to select an “enumerated” value) or by using checkboxes to turn a parameter setting on and off.

In all cases, the parameter has to be selected by placing focus on it and then editing has to be enabled before its value can be changed.

The rollkey and cursor keys on the front panel are provided for navigation and selection of parameters.

The numeric keypad, rollkey and cursor keys on the front panel and an external keyboard (optional) are provided for the entry of parameter values.

Numeric Keypad



The numeric keypad is provided for entry of numeric parameters. It contains the following keys:

- Number keys 0 to 9
Starts editing of the selected parameter. This enables a new value to be entered for a parameter directly without having to press *ENTER* first. The digit will be displayed as the first digit of the newly entered value. Inserts a digit at the cursor position when editing an alphanumeric parameter.
- Decimal point
Inserts a decimal point “.” at the cursor position.
- Sign key (“-“)
Changes the sign of the mantissa or exponent of a numeric parameter. A “-“ is inserted at the cursor position when editing an alphanumeric parameter.
- Unit keys (GHz/-dBm, MHz/dBm, kHz/dB and Hz/dB)
- Provides the numeric value entered with the selected unit and sets the parameter to that value.
The unit keys are all assigned the value “1” for dimensionless quantities or for level entries (e.g. in dB). The unit keys thus assume the function of an *ENTER* key.
- *BACK* key
Deletes the character to the left of the cursor with alphanumeric entry.
- *ESC/CANCEL* key
Aborts the entry of a new parameter value. The previous value is restored. Closes pop-up dialogs.
- *ENTER* key
Enables editing of the selected parameter (using numeric keys or rollkey). Finishes the editing of a parameter value. The new value is set. For an alphanumeric value, the new value is set to that displayed (using the current unit if applicable).
In a drop-down menu, the parameter is set to the currently selected value in the list.

Rollkey

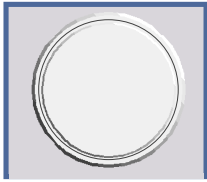



The rollkey has various functions:

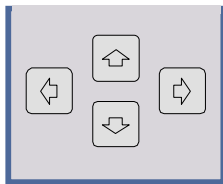

- In a settings view, the rollkey can be used to navigate between individual parameters (the parameter selected being highlighted).
- In drop-down menus, the rollkey can be used to navigate between the individual values for the parameter.
- During numeric entry, the parameter is incremented (by turning clockwise) or decremented (by turning counter-clockwise) at a defined step size (depending on the parameter).
- In setting views and data entry dialogs pressing the rollkey invokes the input of parameters or immediately sets the new value, i.e. pressing the rollkey is like pressing the ENTER key.
- In drop-down menus, pressing the rollkey selects the relevant item.

Cursor Keys



The keys  and  are used to:

- Navigate between individual parameters within the setting views and some of the pop-up dialogs.
- Navigate between the individual values within drop-down menus.
- Move the cursor left & right inside the entry window to reach a particular position in the string during alphanumeric entry.

The keys  and  are used to:

- Navigate between individual parameters within the setting views and some of the pop-up dialogs.
- Navigate between the individual items within drop-down menus.
- Increment or decrement the value of a parameter during numeric entry.

Selection of a parameter within a settings view

Selection using rollkey

- Press *SET FREQ* softkey for example (Frequency settings view is displayed).
- Rotate the rollkey until reaching the required parameter. Turning the rollkey clockwise selects parameters in the upward direction, turning it counter-clockwise selects parameters in the downward direction.

Example: Selecting *Image Rejection* (Frequency settings)

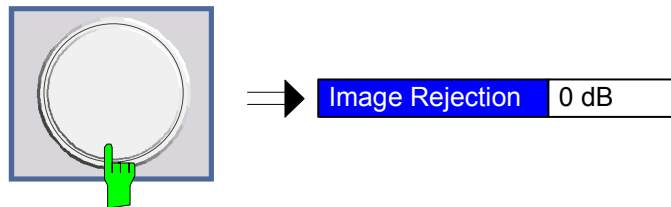

Note: *When the Image Rejection parameter is selected its label is highlighted blue.*

When the desired parameter is reached press the rollkey to edit the parameter.

Selection using cursor keys

- Cursor  ,  ,  or  until obtaining the required parameter.

Within a list of parameters, the *Down* and *Right* both move to the next item (down) in the list and the *Up* and *Left* keys both move to the previous item (up) in the list.

Within a table of parameters, the cursor keys move the cursor in the direction indicated.

- To start editing the parameter, either press the *ENTER* key on the numeric keypad, or press the rollkey.
- For numeric parameters, editing can also be started by entering the new value directly from the numeric keypad without pressing the *ENTER* key first.

Example: Selecting Mode (Frequency settings)

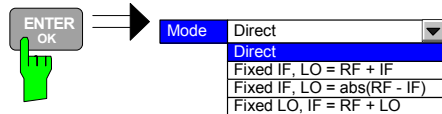
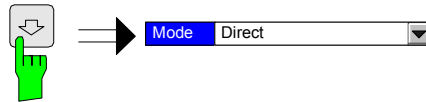

Note: When *ENTER* is pressed, a drop-down menu is displayed, which contains all the available settings to which the *Mode* parameter can be set.

Selection using mouse

- Use the mouse to move the cursor to the parameter and press the left mouse button to select the parameter.
- To start editing the parameter, either press the *ENTER* key on the numeric keypad, or press the rollkey.

For numeric parameters, editing can also be started by entering the new value directly from the numeric keypad without pressing the *ENTER* key first.

Selection using external keyboard

- Select parameter using the cursor keys (in the same way as using the cursor keys on the front panel).
- To start editing the parameter, either press the *ENTER* key on the numeric keypad, or press the rollkey.

For numeric parameters, editing can also be started by entering the new value directly from the numeric keypad without pressing the *ENTER* key first.

Entry of a numeric value

Once a parameter has been selected (see above), a new value for a numeric parameter can be entered in a number of ways. With the exception of entry via the number keys, to start editing the parameter, either press the *ENTER* key on the numeric keypad, or press the rollkey before following the instructions below.

If an error occurs, for example, the entered value is out of range, then the new value will not be accepted for the parameter setting.

Entry using number keys (numeric keypad)

- Enter required value using the number keys.

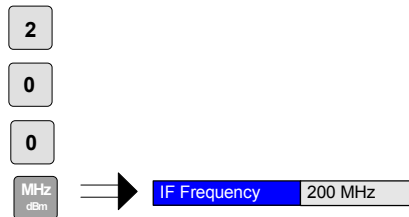

Example: To enter 200 MHz



Note: *The parameter is not set to the new value until either one of the unit keys on the numeric keypad, the ENTER or the rollkey is pressed.*

If the new value is not valid, then a message box is displayed and the entered value will be replaced with a valid value. For example, when a value above the maximum allowed is entered, then the maximum value allowed will be shown in the entry box. The parameter will still be ready for editing so that another value can be entered if desired.

Entry using cursor keys

- Cursor  or  until obtaining the required value.

The application prevents the minimum and maximum values of the parameter from being exceeded and displays an “Out of range” message box if attempted.

N.B The cursor keys increment/decrement a parameter value in large steps.

Example: Cursor down to 100MHz

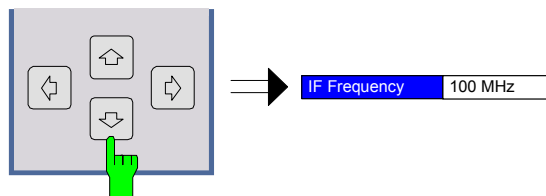

Note: *Each change of the parameter value takes place immediately. No other keys need to be pressed.*

Entry using rollkey

- Rotate the rollkey until reaching the required value.
- Turning the rollkey clockwise increases the value, turning it counter clockwise decreases the value.

The application prevents the minimum and maximum values of the parameter from being exceeded and displays an “Out of range” message box if attempted.

N.B The rollkeys increment/decrement a parameter value in small steps.

Example: Rotate to 200MHz

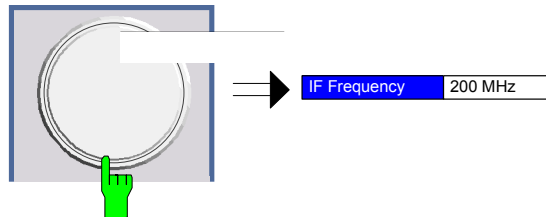

Note: *Each change of the parameter value takes place immediately. No other keys need to be pressed.*

Entry using external keyboard**Terminating the entry**

- Enter value using number keys 0 – 9 in the same way as for using the number keys on the numeric keypad (see above).
- Press one of the unit keys on the numeric keypad.

The unit is entered in the parameter's edit box and the new parameter value is set immediately.



- Press the *ENTER* key (on numeric keypad or external keyboard) or press the rollkey.

The new parameter value is set immediately.

Note: *Pop-up dialogs, where used, do not close automatically. They can be closed by pressing the ESC key.*

In both cases, if the new value is not valid, then a message box is displayed and the entered value will be replaced with a valid value. For example, when a value above the maximum allowed is entered, then the maximum value allowed will be shown in the entry box. The parameter will still be ready for editing so that another value can be entered if desired.

Correcting the entry

- Position the cursor to the right of the digit which is to be deleted using the cursor keys  or .
- Press the BACK key. The digit to the left of the cursor is deleted.
- Enter new digits. Each digit is inserted to the left of the cursor, the other digits are shifted right.

Aborting the entry



- Press the *ESC* key during parameter editing.
The original parameter value is restored. The new entry is deleted.
- If a pop-up dialog is displayed, press the *ESC* key again.
The entry window is closed, the original value remains active.

Entry of an enumerated value

Once a parameter has been selected (see above), a new value for an enumerated parameter can be entered in a number of ways. To start editing the parameter, either press the *ENTER* key on the numeric keypad, press the rollkey or left click with the mouse on the drop down button before following the instructions below.

Note: *When the rollkey or ENTER is pressed, a drop-down menu is displayed, which contains all the available settings that may be selected for the parameter.*

Selection of setting using cursor keys

- Cursor  or  until obtaining the required setting.
- Press *ENTER* on external keyboard or numeric keypad, or press rollkey to select the desired setting of parameter.

Note: *Currently selected setting of the parameter is highlighted blue. Pressing ENTER sets the new setting of the parameter immediately.*

Selection of setting using rollkey

- Rotate the rollkey until reaching the required setting.
- Press rollkey to select setting.

Example: Select *Mode* parameter.

Note: *Currently selected setting of the parameter is highlighted blue. Pressing the rollkey sets the new setting of the parameter immediately.*

Selection of setting using mouse

- When the parameter is selected and ready for editing, select a new setting using the mouse by left-clicking on the new setting from the drop-down list. The new setting of the parameter is set immediately.

Selection of setting using external keyboard

- Select setting using cursor keys.
- Press *ENTER* to set the parameter to the new value.

Entry of a checkbox

A checkbox is used for parameter settings that are either On or Off (Boolean settings). A checkmark (✓) appears in the box when the setting is On; the checkbox is empty when the setting is Off.

Once a parameter has been selected (see above), a new value for a Boolean parameter can be entered in a number of ways. Because Boolean parameters are very simple, it is not necessary to press the *ENTER* key on the numeric keypad or to press the rollkey in order to edit them.

Toggle between the two states of a checkbox using rollkey

- Press the rollkey to toggle between the two states.

Example: Turn *2nd Stage Correction* setting to Off

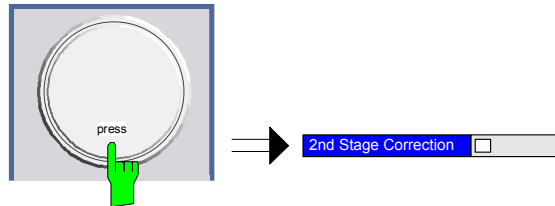

Note: The checkbox is empty when the settings is Off.

Toggle between the two states of a checkbox using numeric keypad

- Press the *ENTER* key to toggle between the two states.

Example: Turn *2nd Stage Correction* setting to On

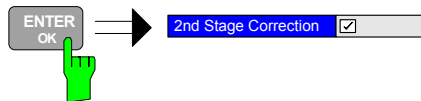

Toggle between the two states of a checkbox using a mouse

- Left-click on the checkbox to toggle between the two states.

Toggle between the two states of a checkbox using external keyboard

- Press *ENTER* to toggle between the two states.

Table Navigation

In R&S FS-K30 some of the settings views contain tables of data (for example the frequency table in the Frequency Settings view). Initially when navigating through the settings in a view only the header of a table can be selected

Selecting & Editing parameters in a table

- Select the table header using the rollkey or cursor keys

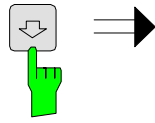

Frequency Table			
RF	LO	IF	Image
550 MHz	10 MHz	560 MHz	570 MHz
552 MHz	10 MHz	562 MHz	572 MHz
554 MHz	10 MHz	564 MHz	574 MHz
556 MHz	10 MHz	566 MHz	576 MHz
558 MHz	10 MHz	568 MHz	578 MHz
560 MHz	10 MHz	570 MHz	580 MHz
...

- Press rollkey or the *ENTER* key to select the first field in the table

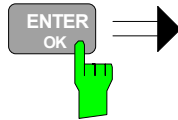

Frequency Table			
RF	LO	IF	Image
550 MHz	10 MHz	560 MHz	570 MHz
552 MHz	10 MHz	562 MHz	572 MHz
554 MHz	10 MHz	564 MHz	574 MHz
556 MHz	10 MHz	566 MHz	576 MHz
558 MHz	10 MHz	568 MHz	578 MHz
560 MHz	10 MHz	570 MHz	580 MHz
...

- The fields in the table can now be navigated around and edited in the same ways as the other settings in the view.
- Once the required changes have been made in the table press the *ESC* key to exit the table.
- The table heading will be highlighted once more

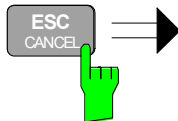

Frequency Table			
RF	LO	IF	Image
550 MHz	10 MHz	560 MHz	570 MHz
552 MHz	10 MHz	562 MHz	572 MHz
554 MHz	10 MHz	564 MHz	574 MHz
556 MHz	10 MHz	566 MHz	576 MHz
558 MHz	10 MHz	568 MHz	578 MHz
560 MHz	10 MHz	570 MHz	580 MHz
...

Status Bar & Title Bar

Title Bar

The title bar is visible at the very top of the display when R&S FS-K30 is active and no settings views are displayed.



Fig. 1-8 Title Bar

The centre of the title bar shows the name of the active application. For R&S FS-K30, this is "NOISE & GAIN".

On the left of the title bar, the current measurement mode (frequency list calculation mode) is displayed.

On the right of the title bar, the calibration status of R&S FS-K30 is displayed. Note that "CALIBRATED" means that R&S FS-K30 is calibrated and does not indicate whether the spectrum analyzer itself is calibrated or not. The calibration status of R&S FS-K30 is only displayed when second stage correction is switched on, because the calibration status of the option is not taken into account in measurements when the second stage correction is switched off.

Status Bar

The main status bar is displayed at the bottom of the display, just above the hotkeys.

When a parameter in a settings view is selected, the status bar will display the minimum and maximum, settings for the selected parameter (see Fig. 1-9).

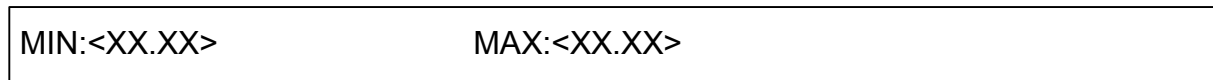

Fig. 1-9 Status Bar

When a parameter whose value is enumerated or Boolean in type is selected in any dialog, the status bar will show "N/A" displayed for the minimum and maximum, since the minimum and maximum values are "Not Applicable."

At other times, the status bar shows the current measurement status along with detailed information about the progress through any running measurement.

The status bar is also used to display warning and error messages to the user. In order to highlight these messages, warning messages are displayed with a blue background and error messages with a red background. Refer to Section 1 for a list of warning and error messages.

Save/Recall

This section of the user manual describes the Save/Recall facility of the option.

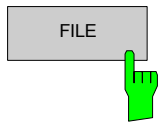

The *FILE* hardkey brings up the Save/Recall softkey menu. Any settings views on display when the save/recall softkey menu is displayed shall be closed.



Figure 1-10: Save/Recall softkey menu

The save/recall facility provided by R&S FS-K30 is exactly the same as that provided by the host analyser. Refer to the user manual for the spectrum analyser for details of the save/recall facility operation.

The save/recall facility in R&S FS-K30 provides the following items that can be saved and/or recalled:

- Current Settings – All user settings provided by R&S FS-K30
- All Limit Lines – Noise & Gain limit lines
- All Traces – The current set of measurement results.
- ENR – All data entered in the ENR Settings view.
- Loss Settings – All loss input & output data from the Loss settings view.

N.B. Items in bold are items also available in the Spectrum Analyser.

To close the save/recall softkey menu and return to the main R&S FS-K30 softkey menu, press the *NOISE* hotkey.

Printing

This section of the user manual describes print facility of the option

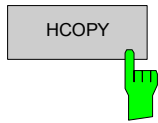

The *HCOPY* hardkey brings up the print softkey menu. Any settings views on display when the print softkey menu is displayed shall be closed.



Fig. 1-11: Print softkey menu

The print facility provided by FS-K30 is exactly the same as that provided by the host analyser. Refer to the user manual for the spectrum analyser for details of the print facility operation.

To close the print softkey menu and return to the main R&S FS-K30 softkey menu, press the *NOISE* hotkey.

Limit Line

This section of the user manual describes limit line facility of the option.

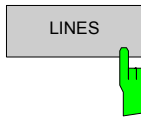

The *LINES* hardkey brings up Limit Line selection view and softkey menu. Any settings views on display when the limit lines selection view is displayed shall be closed.

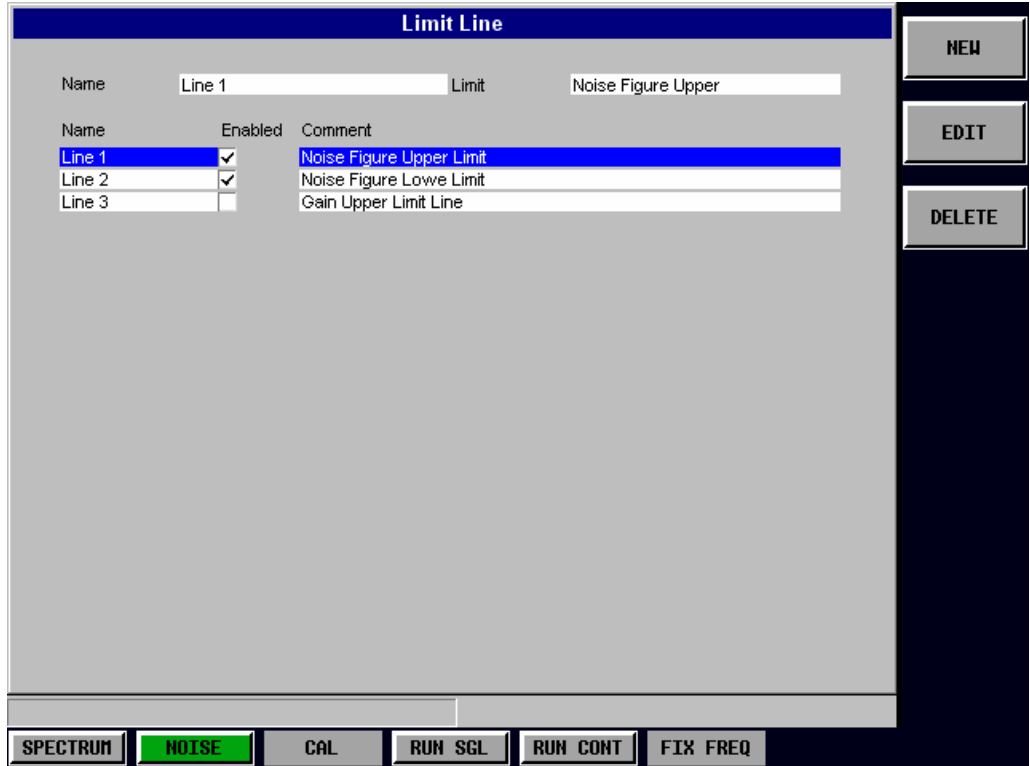
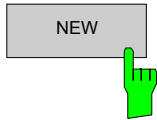

Fig. 1-12 Limit Line selection view

From the Limit Line selection view it is possible to add new limit lines, edit existing limit lines, delete limit lines and enable/disable the display of limit lines.

Adding Limit Lines

New limit lines can be defined by pressing the *NEW* softkey from the limit line selection softkey menu.



The *NEW* softkey allows a new limit line to be defined. After pressing the *NEW* softkey the limit line selection view will be replaced with the limit line data view.

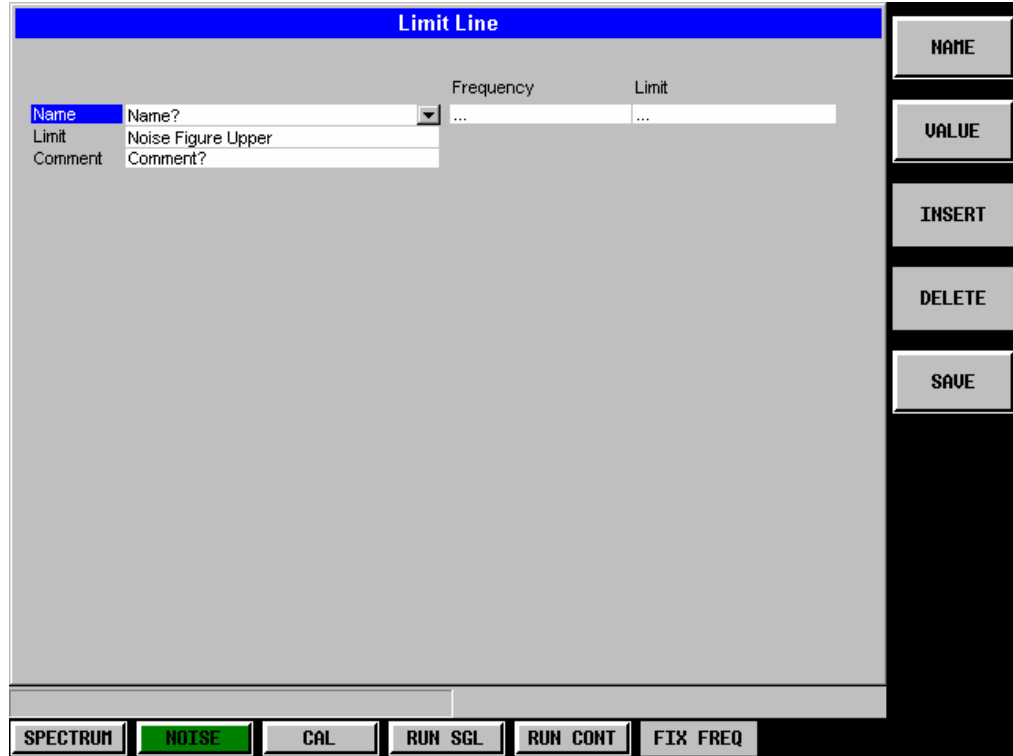

Fig. 1-13 Limit Line data view (for a new limit line)

Once the limit line data has been entered as required, press the *SAVE* softkey to save the changes. Pressing the *ESC* hardkey will display a prompt requesting whether the limit line data should be stored or not. Select the appropriate response with the cursor keys or rollkey and hit *ENTER* or press the rollkey to perform the selected action.

Name



The *Name* field allows each limit line to be uniquely identified. The name can contain any combination of number, letters and characters. Each limit line must have a unique name. An error message will be displayed if a new limit line is added with the same name as an existing limit line. Pressing the *NAME* softkey will cause the *Name* field to be selected.

Limit



The *Limit* field specifies the type of result that this limit line applies to (Noise or Gain) and the type of limit that should be applied (Upper or Lower).

Comment

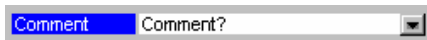

The *Comment* field allows the user to attach a textual description to a limit line. The comment can contain any combination of number,

letters and characters.

Frequency / Limit Table

The *Frequency/Limit Table* lists the Limit values for different Receive Frequency (*RF*) values. R&S FS-K30 will interpolate between points in the list for *RF* values used in a measurement that are not explicitly entered in the Frequency/Limit list.

When focus is moved to the Frequency/Limit Table at the bottom left of the view, the current parameter in the table is highlighted. Navigation through the table is possible in all four directions using the cursor keys.

It is possible to add individual values directly into the Frequency/Limit Table, including insertion and deletion of *RF/Limit* value pairs (rows in the list). The list can contain up to 100 *RF/Limit* value pairs. Note that the order of *RF* values must be in ascending sequence.

Limit Line			
		Frequency	Limit
Name	line 1	550 MHz	10
Limit	Noise Figure Upper	551 MHz	12
Comment	Noise Figure Upper Limit	555 MHz	12
		557 MHz	11
		559 MHz	11
	

Fig. 1-14 Frequency/Limit table

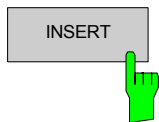

The *INSERT* softkey inserts a new row in the Limit Table directly above the row currently selected. The cursor will be moved to the corresponding column in the new row ready for detailed entry. The *INSERT* softkey shall be disabled when the maximum number of entries in the Limit Table has been reached.

Limit Line			
		Frequency	Limit
Name	line 1	550 MHz	10
Limit	Noise Figure Upper	551 MHz	12
Comment	Noise Figure Upper Limit	555 MHz	12
		557 MHz	11
		559 MHz	11
	

Fig. 1-15 Inseting limit line data

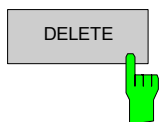

The *DELETE* softkey deletes the currently selected row in the Limit Table. Note that no confirmation is required for this action. The cursor will be moved to the corresponding column in the next row.

Modifying Limit Lines

Existing limit lines can be modified by pressing the *EDIT* softkey from the limit line selection softkey menu

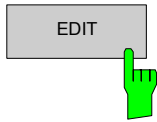

The *EDIT* softkey allows the limit line selected in the limit line selection view to be modified. After pressing the *EDIT* softkey the limit line selection view will be replaced with the limit line data view containing the limit line data for the selected limit line.

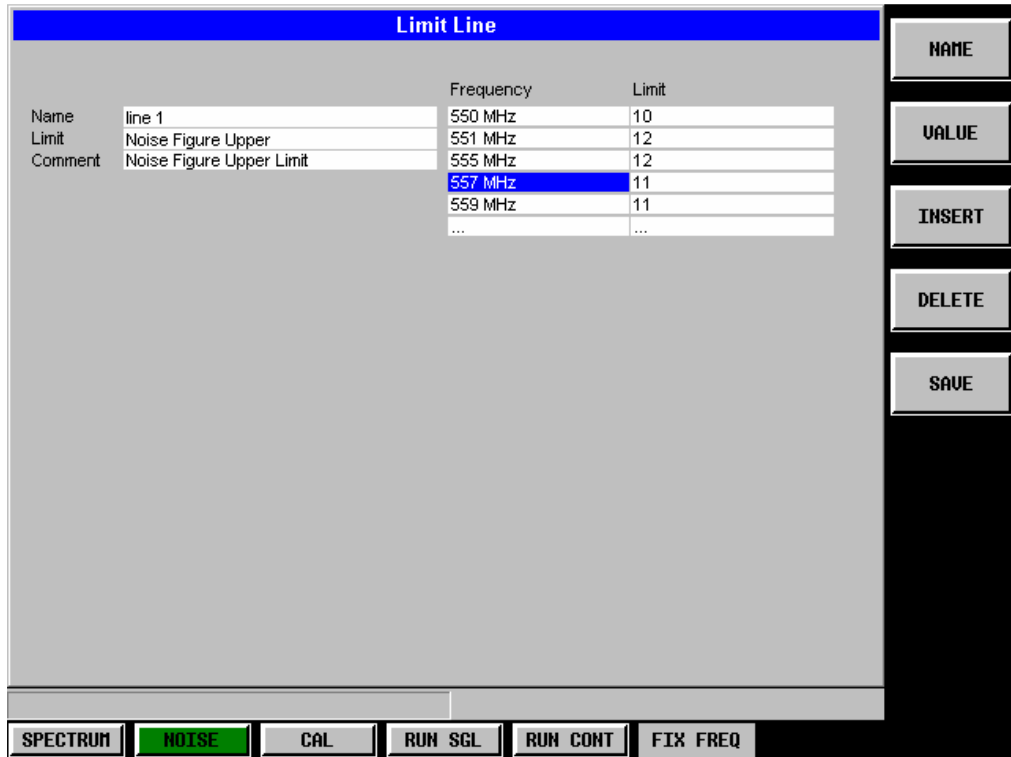
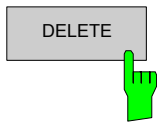

Fig. 1-16 Limit Line data view (for an existing limit line)

Once the limit line data has been modified as required, press the *SAVE* softkey to save the changes. Pressing the *ESC* hardkey will display a prompt requesting whether the changes to the limit line data should be stored or not. Select the appropriate response with the cursor keys or scroll key and hit *ENTER* or press the rollkey to perform the selected action.

Deleting Limit Lines

Existing limit lines can be deleted by pressing the *DELETE* softkey from the limit line selection softkey menu



The *DELETE* softkey allows the limit line selected in the limit line selection view to be deleted.

Enabling / disabling Limit Lines

Limit lines can be enabled and disabled. When a limit line is enabled it will be displayed in the relevant results graph, and limit checking will be performed. When a limit line is disabled it will not be displayed and no limit checking for this line will be performed.

To enable/disable a limit line select the required limit line in the limit line selection view. When the required limit line is highlighted press the ENTER key or press the rolkey to toggle the state of the limit line between enabled and disabled. When a limit line is enabled a ✓ symbol is shown in the *Enabled* field. Note that only one limit line of each type can be active at a given time.

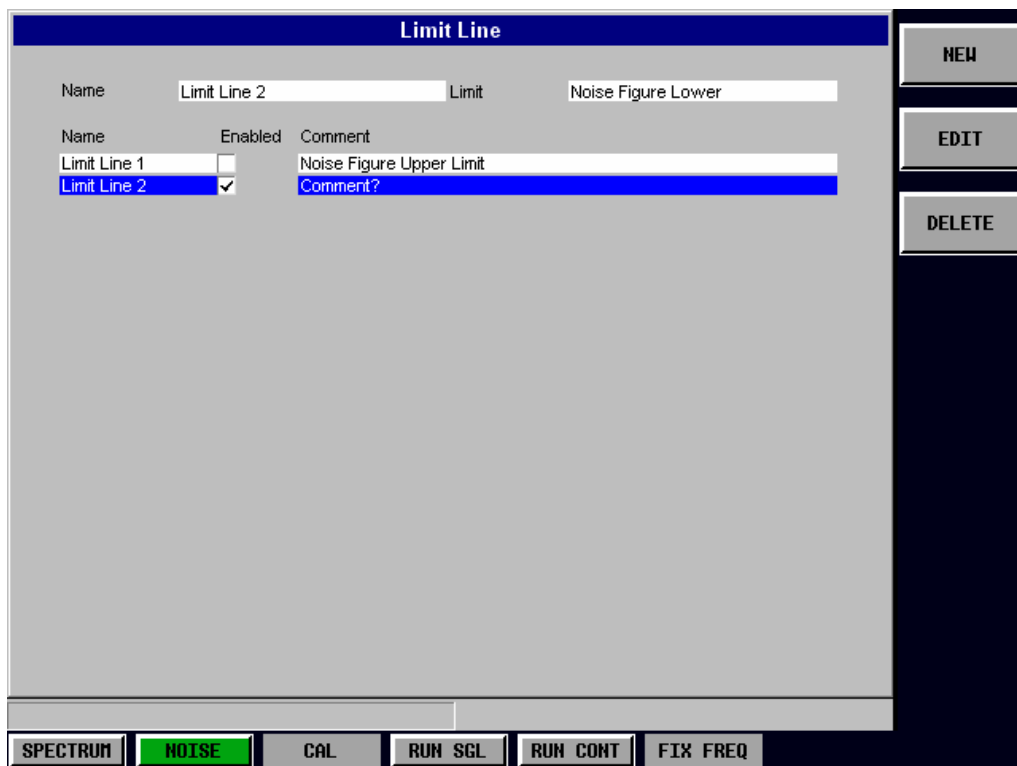
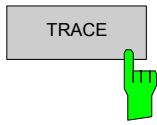

Fig. 1-17 Enabling/Disabling limit lines using the Limit line selection view

Trace Menu

This section of the user manual describes the Trace Memory facility. The trace memory facility is accessed by its own softkey menu.



The *TRACE* hardkey brings up the Trace Memory softkey menu. Any settings views on display when the Trace Memory softkey menu is displayed shall be closed.



Fig. 1-18 Trace Memory softkey menu

The Trace Memory facility allows results displayed graphically to be stored in memory, allowing the results to be compared with subsequent measurements. This facility is recommended in order to graphically compare and document the effects of small changes on the DUT.

In addition to the current measurement results, R&S FS-K30 can store and display up to 3 sets of trace memory results.

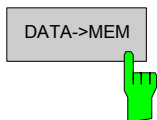

The *DATA->MEM* softkeys (1,2 & 3) allows the current trace results to be transferred to the relevant trace memory. As soon as trace data has been transferred to memory the display of the trace memory line is switched on. When data has been transferred to trace memory the relevant *DATA->MEM* softkey background will be green to show that data is stored. If data is transferred to a trace memory when the trace memory already contains trace data then the new trace data will completely overwrite the current trace data in memory.

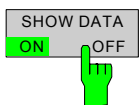

The *SHOW DATA* softkey is used to toggle the display of the current measurement results traces on and off. The display of trace memory results is not affected when this softkey is pressed.

Note that when a new frequency list measurement is started the display of the current result trace is automatically switched on.

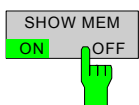

The *SHOW MEM* softkeys (1,2 & 3) are used to toggle the display of the relevant trace memory result on and off. This softkey will not be available if no data is held in the relevant trace memory.



Fig. 1-19 Trace Memory softkey menu next page



The *ASCII FILE EXPORT* softkey stores the active trace in ASCII format on a given disk.

The file consists of the header containing important scaling parameters and a data section containing the trace data.

The data of the file header consist of three columns, each separated by a semicolon:

parameter name; numeric value; basic unit

The data section starts with the keyword "Trace;<n>," (<n> = number of stored trace), followed by the measured data in two columns

which are also separated by a semicolon. The first column contains the frequency value, the second contains the corresponding Phase noise value.

This format can be read in from spreadsheet calculation programs, eg MSExcel.

It is necessary to define ';' as a separator.

Note: *Different language versions of evaluation programs may require a different handling of the decimal point. It is therefore possible to select between separators '.' (decimal point) and ',' (comma) using softkey DECIM SEP.*

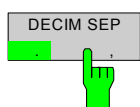

The *DECIM SEP* softkey selects the decimal separator between '.' (decimal point) and ',' (comma) with floating-point numerals for the function ASCII FILE EXPORT.

With the selection of the decimal separator different language versions of evaluation programs (eg MS-Excel) can be supported.

Marker Menu

This section of the user manual describes the Marker facility of the option.

The markers are used for marking points on traces, reading out measurement results and for quickly selecting a display section. R&S FS-K30 provides one marker.

From the marker menu it is possible to adjust the marker position.

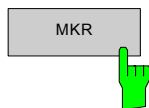

The *MKR* hardkey brings up the Marker softkey menu. Any settings views on display when the Marker softkey menu is displayed shall be closed.



Fig. 1-20 Marker softkey menu

Adjusting Markers

The marker can be adjusted by pressing the marker softkey in the marker softkey menu

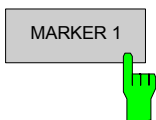

The *MARKER 1* softkeys displays the Marker 1 pop-up dialog.

As soon as a field in the marker pop-up dialog is adjusted then the marker position in the trace will update, along with the results displayed for the marker.

Toggle Marker Display

Markers can be toggled by pressing the Marker soft-key as follows:

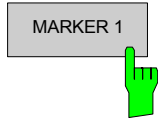

Pressing the *MARKER* softkey when the marker is not displayed (softkey has grey background) causes the Marker pop-up to be displayed and the marker to be switched on. The associated marker then become the currently active marker.

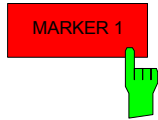

Pressing the *MARKER* softkey when the Marker pop-up is displayed (softkey has red background) causes the marker to be switched off.

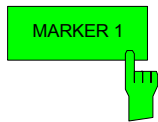

Pressing the *MARKER* softkey when the Marker is displayed but the Marker pop-up is not displayed (softkey has green background) causes the Marker pop-up to be displayed.

All markers in the active screen can be switched off by pressing the *ALL MARKER OFF* softkey.

Assigning Markers to Traces

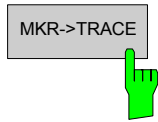

Pressing the *MKR->TRACE* displays the Select Trace pop-up dialog. This allows the marker to be assign to the Noise or the Gain trace.

MKR-> Menu



Fig. 1-21 MKR-> softkey menu

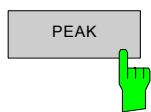

The *PEAK* softkey sets the active marker to the peak of the trace. If no marker is active when **MKR->** menu is called, *MARKER 1* is automatically switched on and the peak search is performed.

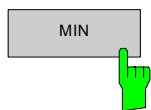

The *MIN* softkey sets the active marker to the minimum of the selected trace. If no marker is active when **MKR->** menu is called, *MARKER 1* is automatically switched on and the min search is performed.

2 Measurements & Settings

This section contains a detailed description of all measurement modes, settings & results. It covers the following subjects:

- Measurement modes & schematics
- Calibration
- Running measurements
- Measurement results
- Frequency settings
- Measurement settings (including control of External Signal Generator)
- ENR settings
- Loss settings
- Graphic settings
- General hints about noise measurements

Measurement modes & schematics

Noise measurements are performed on many different types of Device Under Test (DUT). The type of DUT to be measured determines the test set-up and also how the frequency list is to be generated.

To support these different types of DUT, R&S FS-K30 provides five different measurement modes:

- Direct
- Fixed IF, $LO = RF + IF$
- Fixed IF, $LO = \text{abs}(RF - IF)$
- Fixed LO, $IF = RF + LO$
- Fixed LO, $IF = \text{abs}(RF - LO)$

The *Measurement Mode* can be selected in the Frequency Settings view by pressing the *SET FREQ* softkey.

R&S FS-K30 also provides a schematic display of the test set-up for each of the above measurement modes. This provides a diagrammatic summary of the test set-up and frequency ranges. It cannot be used to enter or change any settings. The schematic display can be viewed by pressing the *SCHEMATIC* softkey within the Frequency Settings view. The upper part of the display shows the set-up for calibration and the lower part of the display shows the test set-up for the measurement proper.

Direct measurements

The Direct setting should be used for DUTs without frequency-conversion, for example, amplifiers. In such cases, a local oscillator is not required and the frequency being measured is the RF frequency.

The schematic display for a Direct measurement mode is shown in Fig. 2-1.

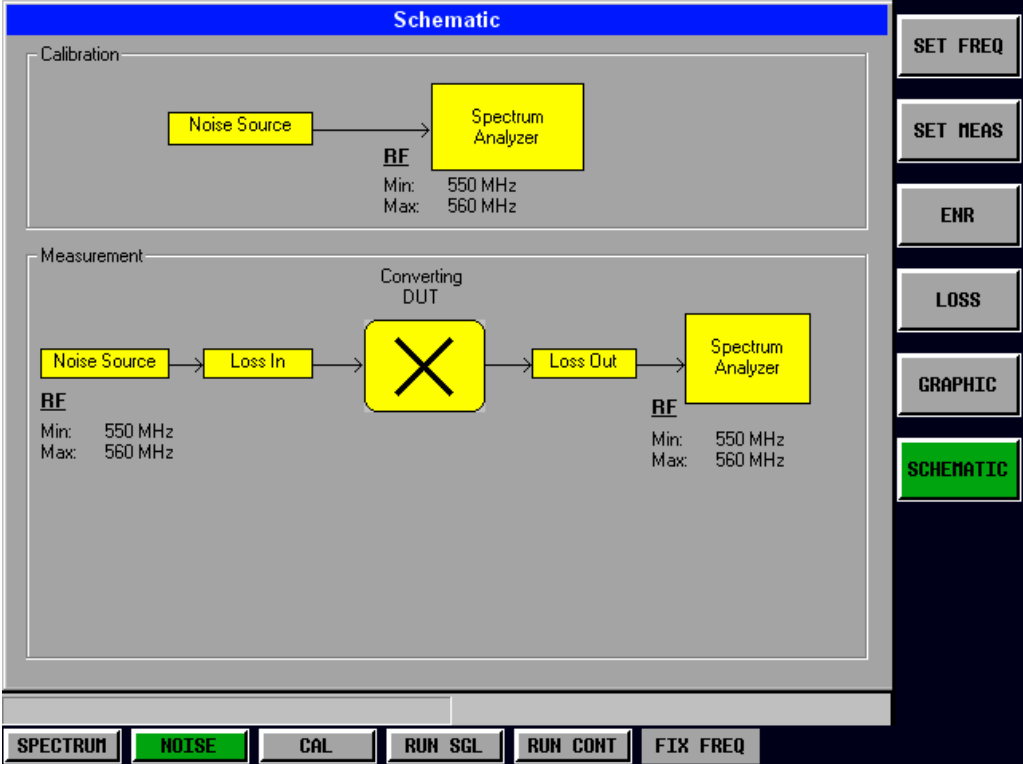

Fig. 2-1 Schematic diagram for direct measurements

Frequency-converting measurements

There are four types of frequency-converting measurements: two with a fixed intermediate frequency (IF) and two with a fixed Local Oscillator (LO) frequency. All have a similar test set-up (schematic) an example of which is shown below (the example shown is for a Fixed IF, $LO = RF + IF$ measurement mode).

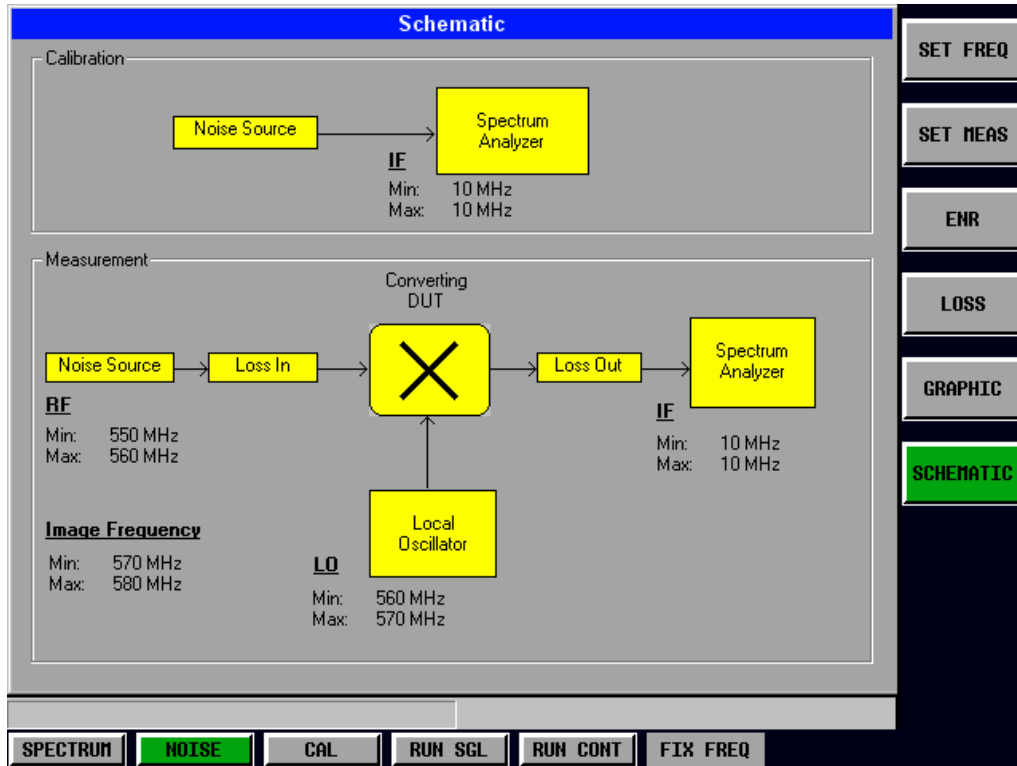

Fig. 2-2 Schematic diagram for frequency converting measurements

The Image Frequency displayed in the schematic indicates the range of the image frequency for the current measurement set-up. This allows the user to determine whether image frequency filters are required and for which frequency range the image rejection of the DUT needs to be entered in the *Image Rejection* setting (of the Frequency Settings view).

The two Fixed IF calculations should be used for frequency-converting DUTs that have a fixed intermediate frequency (IF), for example, mixers. These options produce a frequency list with a constant IF frequency for each measurement step but with a LO frequency which varies from step to step according to the calculation selected. The application will control an external signal generator (via the IEC bus) to generate the LO signal. It is also possible to drive a voltage source that controls a VCO which generates the LO signal.

The two Fixed LO calculations should be used for frequency-converting DUTs that have a fixed Local Oscillator (LO) frequency, for example, satellite converters with a fixed LO frequency. These options produce a frequency list with a constant LO frequency for each measurement step but with an IF frequency which varies from step to step according to the calculation selected.

Calibration

Calibration of the R&S FS-K30 application measures the noise introduced to a signal by the spectrum analyzer itself.

This can then be compensated for in measurements on a Device Under Test. This compensation is called 2nd Stage Correction, because the spectrum analyzer is the second stage of the test set-up, the DUT being the first stage.

The 2nd Stage Correction setting can be found in the Measurement Settings view by pressing the *SET MEAS* softkey.

The calibration status of the R&S FS-K30 application is shown on the right-hand-side of the Title Bar at the top of the screen. Note that this status is the status of R&S FS-K30 only and does not indicate if the spectrum analyzer itself is calibrated. If the spectrum analyzer is uncalibrated, then a red "UNCAL" label will appear to the left of any measurement results graph.

When any change is made to the Frequencies List, that is, the list of Receive Frequencies (*RF*) at which measurements will be made, R&S FS-K30 will need to be calibrated again. This is necessary to ensure that there is calibration data available for every measurement step for the current measurement mode. The Frequencies List can be found in the Frequency Settings view by pressing the *SET FREQ* softkey.

The procedure for performing a calibration of R&S FS-K30 is as follows:

- Connect the noise source to the RF input of the spectrum analyzer. (see Fig. 2-3)
- Connect the supplied low-pass filter to the voltage supply input of the noise source.
- Provide the voltage supply for the noise source by connecting it to the +28V socket of the analyzer (labelled NOISE SOURCE at the rear of the instrument) via a coax cable and the low-pass filter. The low-pass filter is connected between the noise source itself and the NOISE SOURCE socket of the analyzer as shown.

The purpose of the low-pass filter is to suppress any interference (e.g. due to RF interference), including interference from the supply line. This makes it possible to perform very precise measurements.

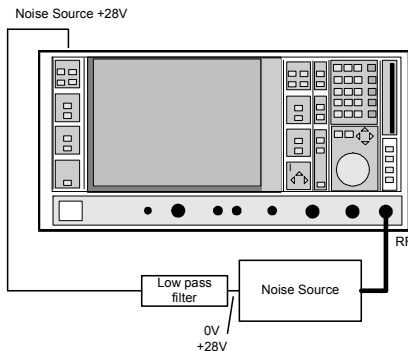

Fig. 2-3 Preparation for calibration

- Set the *Second Stage Correction* parameter in the Measurement Setting view to ON. Calibration cannot be performed until this parameter is set.
- Start the calibration of R&S FS-K30 by pressing the *CAL* hotkey.

During calibration, the text "*Running...*" is displayed in the Status Bar at the bottom of the screen. The progress bar indicates the progress through the calibration measurement.

After successful calibration, the Status Bar will display "*Measurement Complete*" and the Title Bar at the top of the screen will show a *CALIBRATED* status on the right-hand-side.

Note that this calibration measurement calibrates only the R&S FS-K30 application and not the spectrum analyzer itself.

Running measurements

There are two forms of measurement that can be started by **R&S FS-K30**:

- Frequency List measurement – a measurement is performed at each of the frequencies listed in the frequency list (in the Frequency Settings view). A frequency list measurement can be run in one of two different modes (single or continuous). A Frequency list measurement run in single mode will measure each frequency point once and complete. A continuous frequency list measurement will measure each point in the frequency list and continue to measure each point in the frequency list in turn until the user aborts the measurement.
- Fixed Frequency measurement – a continuous measurement is performed at the single frequency currently selected in the measurement results table.

The frequency list measurement is the normal measurement of R&S FS-K30, since this measures the noise figure and gain of the DUT across a user-specified range of frequencies. The fixed frequency measurement is provided so that one individual frequency from a frequency list measurement can be investigated in more detail, for example to see the effect of dynamic changes to the noise figure of the DUT at a particular frequency.

To start a frequency list measurement, press the *RUN SGL* hotkey (single) or *RUN CONT* hotkey (continuous). To start a fixed frequency measurement, press the *FIX FREQ* hotkey.

Because the fixed frequency measurement requires the user to select a measurement point (frequency) from the measurement results table, it is not possible to run a fixed frequency measurement until after a frequency list measurement has been completed. The *FIX FREQ* hotkey will therefore be disabled until a frequency list measurement has been run.

Always perform calibration before running measurements. It is possible to run measurements when R&S FS-K30 is uncalibrated, but the measurement results will not be corrected for any noise introduced by the spectrum analyzer itself.

Note that if one measurement is started whilst another measurement is in progress, for example, a Single Frequency measurement is started whilst a Frequency List measurement is in progress, then the first measurement will be aborted and the new measurement started immediately.

During a measurement, the text "*Running...*" is displayed in the Status Bar at the bottom of the screen.

For a frequency list measurement, the progress bar indicates the progress through the measurement. Note that for a continuous frequency list measurement the progress bar represents the progress through the current iteration of the frequency list. Measurement results are updated as the measurement is in progress. After successful completion of a frequency list measurement, the Status Bar will display "*Measurement Complete*"

For a fixed frequency measurement, the measurement results are continuously updated in the "Current Results" section of the results table at the top of the screen. The results graph and table in the bottom half of the screen do not change – these are the results of the last Frequency List measurement. Because the fixed frequency measurement is continuous, it does not stop until it is aborted by pressing the *FIX FREQ* hotkey again or by starting another measurement.

Measurement results

Frequency List measurements

After successful completion of a Frequency List measurement, the display will show either a graphical or list (tabular) view of the measurement results, depending on the currently selected view.

All of the settings for the measurement results view can be found in the Graphic Settings view (press the *GRAPHIC* softkey). Two typical views are shown below.



Fig. 2-4 A typical graphical display of measurement results



Fig. 2-5 A typical tabular display of measurement results

The tabular section below the title bar shows the overall measurement settings used for the last measurement. This includes the following:

- RBW: Resolution Bandwidth (Hz)
- Average
- RF Atten: RF Attenuation (dB)
- Ref Meas: Manual if the reference level is manually entered, Automatic if the reference level is measured automatically before each measurement
- 2nd Stage Corr.: On if 2nd stage correction is applied using calibration data, Off if no correction is applied to the measurement results
- Image Reject: image rejection of the DUT (dB)

The Current Value section of the table shows the settings and measurement results for the currently selected measurement point in the frequency list. At the completion of a measurement, this will display the settings & results of the last point in the list. When another point in the frequency list is selected, the Current Value section will update accordingly. This includes the following:

- RF: Receive Frequency at the DUT at which the current values were measured (Hz)
- LO: Local Oscillator frequency (Hz) – not displayed for Direct measurements
- IF: Intermediate Frequency (Hz) – not displayed for Direct measurements
- ENR: ENR value (dB) – refers to the Receive Frequency (RF)
- Loss In: Loss at the Input of the DUT (dB) – refers to the Receive Frequency (RF)
- Loss Out: Loss at the Output of the DUT (dB) – refers to the Intermediate Frequency (IF) for all measurements except Direct measurements where it refers to the Receive Frequency (RF)
- NF: Noise Figure measured (dB)
- Noise Temp: Noise Temperature (K) derived from measured Noise Figure
- Gain: Gain measured (dB)

The bottom section of the table displays either a list or a graph of the complete set of points defined in the frequency list for the measurement.

A graphical view will include either one or two traces. The Noise trace will be the same colour as Trace 1 in the spectrum analyzer (yellow by default) and the Gain trace will be the same colour as Trace 2 in the spectrum analyzer (blue by default).

A list view consists of a table listing detailed results for each frequency at which a measurement was performed as follows:

- RF: Receive Frequency at the DUT at which the values in this row of the table were measured (Hz)
- LO: Local Oscillator frequency (Hz) – not displayed for Direct measurements
- IF: Intermediate Frequency (Hz) – not displayed for Direct measurements
- NF: Noise Figure measured (dB)
- Noise Temp: Noise Temperature (K) derived from measured Noise Figure
- Gain: Gain measured (dB)

By selecting a row within the list, the other settings for each measurement point may also be viewed in the Current Value section of the display (see above). Selecting a row within the list also sets the frequency at which any fixed frequency measurement will be performed (by pressing the *FIX FREQ* hotkey).

Fixed Frequency measurements

A Fixed Frequency measurement runs continuously at the selected frequency. The results are continuously updated in the Current Value section of the display. This always displays the settings and results for the current measurement.

Direct		NOISE & GAIN			
RBW:	1 MHz	RF Atten.	0 dB	2nd Stage Corr.	Off
Average:	1	Auto Ref Level	On	Image Rejection	...
Current Value					
RF:	550 MHz	ENR	15 dB	NF:	0 dB
LO:	...	Loss In	0 dB	Noise Temp.	0 K
IF:	...	Loss Out	0 dB	Gain	0 dB

Fig. 2-6 Current Value area of table of results

The left two columns display the settings being used for the measurement:

- RF: Receive Frequency at the DUT at which the current values were measured (Hz)
- LO: Local Oscillator frequency (Hz) – not displayed for Direct measurements
- IF: Intermediate Frequency (Hz) – not displayed for Direct measurements
- ENR: ENR value (dB) – refers to the Receive Frequency (RF)
- Loss In: Loss at the Input of the DUT (dB) – refers to the Receive Frequency (RF)
- Loss Out: Loss at the Output of the DUT (dB) – refers to the Intermediate Frequency (IF) for all measurements except Direct measurements where it refers to the Receive Frequency (RF)

The right column contains the measurement results. These values will be constantly changing allowing for monitoring of dynamic changes at this frequency.

- NF: Noise Figure measured (dB)
- Noise Temp: Noise Temperature (K) derived from measured Noise Figure
- Gain: Gain measured (dB)

Frequency Settings

This section of the user manual describes the Frequency Settings view where all settings related to frequencies can be modified as well as the measurement mode. This view is also where the schematic display of the selected test set-up can be found.

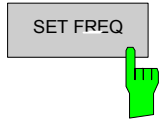

The *SET FREQ* softkey brings up the Frequency Settings view.

Frequency Settings		Frequency Table			
Parameter	Value	RF	LO	IF	Image
Start Freq	220 MHz	220 MHz	220 MHz	0 Hz	220 MHz
Stop Freq	320 MHz	230 MHz	230 MHz	0 Hz	230 MHz
Step Freq	10 MHz	240 MHz	240 MHz	0 Hz	240 MHz
MODE	Fixed IF, LO=RF+IF	250 MHz	250 MHz	0 Hz	250 MHz
Fixed LO	...	260 MHz	260 MHz	0 Hz	260 MHz
Fixed IF	0 Hz	270 MHz	270 MHz	0 Hz	270 MHz
Image Rej	999.99 dB	280 MHz	280 MHz	0 Hz	280 MHz
		290 MHz	290 MHz	0 Hz	290 MHz
		300 MHz	300 MHz	0 Hz	300 MHz
		310 MHz	310 MHz	0 Hz	310 MHz
		320 MHz	320 MHz	0 Hz	320 MHz

Fig. 2-7 Frequency Settings view

The parameters within the Frequency settings view are logically grouped together into:

- Frequency Settings
- Frequency Table

Any parameters that are not available for editing will have a grey background. This usually occurs when one parameter setting makes another parameter invalid, for example if the *Mode* is *DIRECT* then neither a *Fixed LO* nor *Fixed IF* frequency has any meaning, so these parameters are greyed out.

Similarly, for a *DIRECT* measurement, the *LO* and *IF* columns in the Frequencies List are not applicable and so will be greyed out and not available for editing.

When a particular parameter is selected within the Frequency Settings view: the status bar changes to display information about the valid settings for the selected parameter.

The Frequency List on the right of the display lists all of the individual measurement steps that will be performed for a normal measurement (when pressing the *RUN SGL* or *RUN CONT* hotkey). This view allows the user to create the list of measurement steps in two ways:

- By entering values in the Frequency Settings group on the left (*Start Frequency*, *Stop Frequency*, *Step Frequency*, etc.), from which R&S FS-K30 will generate the list of measurement steps on the right. This allows rapid generation of a measurement consisting of up to 100 steps.
- By editing individual values in the Frequencies List on the right, including insertion and deletion of measurement steps. This allows specific adjustments to individual measurement steps to be made in order to customise the automatically generated list, e.g. to insert extra measurement steps near to a specific frequency of interest in order to get more detailed results (but without losing the rest of the frequency range).

Note that when any change is made to the Frequencies List, R&S FS-K30 will need to be calibrated again.

Frequency Settings

The parameters in the Frequency Settings group are used to automatically generate the list of Receive Frequency (*RF*) values for the Frequencies List shown on the right of the settings view.

The *RF* values in the Frequencies List are generated into a list of ascending frequencies as follows (when the *Start Frequency* is less than the *Stop Frequency*):

1. *Start Frequency*
2. *Start Frequency* + *Step Frequency*
3. *Start Frequency* + *Step Frequency* * 2
4. *Start Frequency* + *Step Frequency* * 3
- ...
- n. *Stop Frequency*

If the *Start Frequency* is larger than the *Stop Frequency*, then the *RF* values will be generated into a list of descending frequencies with the *Step Frequency* being subtracted for each step.

If the values for *Start*, *Stop* & *Step Frequency* will result in a Frequencies List of more than 100 measurement steps, only the first 100 *RF* steps will be generated and a warning will be displayed to the user (See Section 4). Reduce the gap between the *Start* & *Stop Frequencies* or increase the *Step Frequency* to reduce the list to 100 points or less.

Start Frequency

Frequency Settings	
Start Freq	220 MHz
Stop Freq	320 MHz
Step Freq	10 MHz
MODE	Direct
Fixed LO	0 Hz
Fixed IF	0 Hz
Image Rej	0 dB

The *Start Frequency* will be the frequency at which the Frequencies List starts, that is, the first Receive Frequency (*RF*) in the list.

Changing the *Start Frequency* will regenerate the list of measurement steps, using the measurement *Mode* selected.

Stop Frequency

Frequency Settings	
Start Freq	220 MHz
Stop Freq	320 MHz
Step Freq	10 MHz
MODE	Direct
Fixed LO	0 Hz
Fixed IF	0 Hz
Image Rej	0 dB

The *Stop Frequency* will be the frequency at which the Frequencies List stops, that is, the last Receive Frequency (*RF*) in the list. If the number of measurement steps in the list reaches 100 steps before the *Stop Frequency* is reached, then the list generation will stop before it reaches the *Stop Frequency* and a warning will be displayed to the user (See Section 4).

Changing the *Stop Frequency* will regenerate the list of measurement steps, using the measurement *Mode* selected.

Step Frequency

Frequency Settings	
Start Freq	220 MHz
Stop Freq	320 MHz
Step Freq	10 MHz
MODE	Direct
Fixed LO	0 Hz
Fixed IF	0 Hz
Image Rej	0 dB

The *Step Frequency* will be the increment (or decrement) in Receive Frequency (*RF*) between each measurement step in the Frequencies List. If the *Step Frequency* is larger than the difference between the *Start Frequency* and the *Stop Frequency* then the Frequencies List will contain just the *Start Frequency* and *Stop Frequency*.

Changing the *Step Frequency* will regenerate the list of measurement steps, using the measurement *Mode* selected.

Mode

Frequency Settings	
Start Freq	220 MHz
Stop Freq	320 MHz
Step Freq	10 MHz
MODE	Direct
Fixed LO	0 Hz
Fixed IF	0 Hz
Image Rej	0 dB

The measurement *Mode* should be selected according to the type of Device Under Test.

R&S FS-K30 provides five different measurement *Modes*:

- Direct
- Fixed IF, $LO = RF + IF$
- Fixed IF, $LO = \text{abs}(RF - IF)$
- Fixed LO, $IF = RF + LO$
- Fixed LO, $IF = \text{abs}(RF - LO)$

Changing the *Mode* will regenerate the list of measurement steps, using the *Start, Stop & Step Frequencies*.

Fixed LO

Frequency Settings	
Start Freq	220 MHz
Stop Freq	320 MHz
Step Freq	10 MHz
MODE	Fixed LO, $IF = RF + LO$
Fixed LO	0 Hz
Fixed IF	0 Hz
Image Rej	0 dB

The *Fixed LO* is the fixed local oscillator frequency for measurement *Modes*.

- Fixed LO, $IF = RF + LO$
- Fixed LO, $IF = \text{abs}(RF - LO)$

Changing the *Fixed LO* will replace all LO values in the Frequencies List (the list of measurement steps).

Fixed IF

Frequency Settings	
Start Freq	220 MHz
Stop Freq	320 MHz
Step Freq	10 MHz
MODE	Fixed IF, $LO = RF + IF$
Fixed LO	0 Hz
Fixed IF	0 Hz
Image Rej	0 dB

The *Fixed IF* is the fixed intermediate frequency for measurement *Modes*.

- Fixed IF, $LO = RF + IF$
- Fixed IF, $LO = \text{abs}(RF - IF)$

Changing the *Fixed IF* will replace all IF values in the Frequencies List (the list of measurement steps).

Image Rejection

Frequency Settings	
Start Freq	220 MHz
Stop Freq	320 MHz
Step Freq	10 MHz
MODE	Fixed IF, $LO = RF + IF$
Fixed LO	0 Hz
Fixed IF	0 Hz
Image Rej	0 dB

The *Image Rejection* is the suppression applied to the second sideband during calculations for measurement *Modes*:

- Fixed IF, $LO = RF + IF$
- Fixed IF, $LO = \text{abs}(RF - IF)$
- Fixed LO, $IF = RF + LO$
- Fixed LO, $IF = \text{abs}(RF - LO)$

The value entered is applied across the complete frequency range. The default value of 999.99 dB means that the second sideband does not noticeably affect the measurement result because a suppression of 999.99 dB is applied to it. This corresponds to the generally used single-sideband (SSB) measurement. An entry of 0 dB would mean that both sidebands are converted to the same extent – this corresponds to a double-sideband (DSB) measurement.

Thus, for a SSB mixer, *Image Rejection* should be set to 999.99 dB. For a DSB mixer (one without any image rejection), the value should be 0 dB. Using an *Image Rejection* value of 999.99 dB for a DSB measurement will produce measurement errors: the measured noise figure will be 3 dB lower than the actual noise figure and the measured gain will be 3 dB higher than the actual gain. For comparison with noise test systems of other manufacturers, the

Image Rejection should be set to 999.99 dB (SSB measurement) as this is the setting implicitly used by almost all manufacturers.

Frequency Table

The *Frequency Table* lists each Receive Frequency (RF) at which a measurement will be performed, along with the corresponding LO, IF & Image frequencies where appropriate.

Whilst the Frequency Table is normally generated automatically using the Frequency Settings group of parameters on the left of the view, it is also possible to add individual values directly into the Frequencies List on the right, including insertion and deletion of measurement steps.

This allows specific adjustments to individual measurement steps to be made in order to customise the automatically generated list, e.g. to insert extra measurement steps near to a specific frequency of interest in order to get more detailed results (but without losing the rest of the frequency range).

If the frequency table is manually modified, all changes will be lost if the start/stop/step frequencies or mode parameters are changed as changing these parameters causes the frequency list to be automatically generated. The frequency table can be regenerated according to the start/stop/step frequencies and mode parameters at any time by pressing the *BUILD TBL* softkey

When focus is moved to the frequency table navigation through the table is possible in all four directions using the cursor keys.

Note that the Frequencies Table details the exact sequence in which measurement steps will be performed. Thus, if the *RF* values are entered out of sequence, then this is the order in which the measurement will be performed.

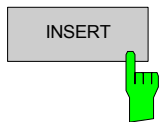

The *INSERT* softkey inserts a new row in the Frequency Settings table directly above the row currently selected. The new row will contain zero values. The cursor will be moved to the corresponding column in the new row ready for detailed entry.

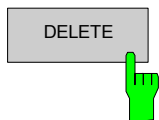

The *DELETE* softkey deletes the currently selected row in the Frequency Settings table. Note that no confirmation is required for this action.

Schematic Diagrams

The Schematic diagram view serves to provide information on the test setup and frequency ranges. The values in the Schematic diagram view are updated every time the frequency ranges are changed

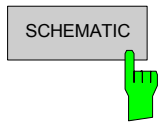

The *SCHEMATIC* softkey brings up the Schematic diagram view.

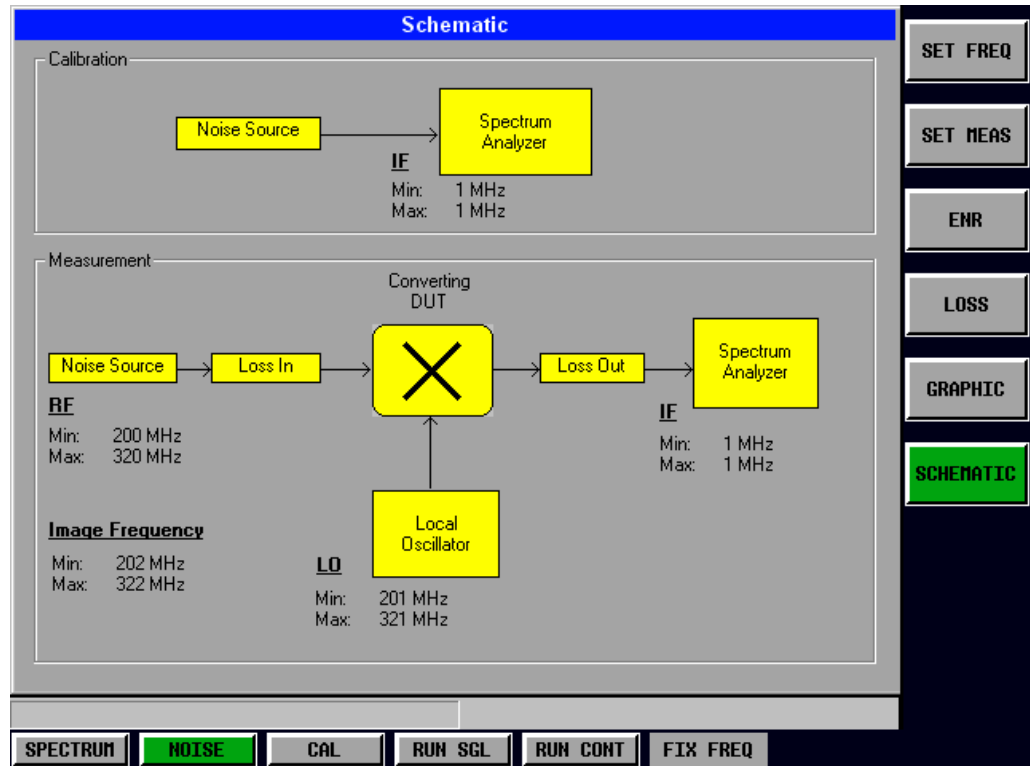

Fig. 2-8 Schematic diagram view

Measurement Settings

This section of the user manual describes the Measurement Settings view where all settings related to the overall measurement can be modified, that is the Calibration, Analyzer & Generator settings.

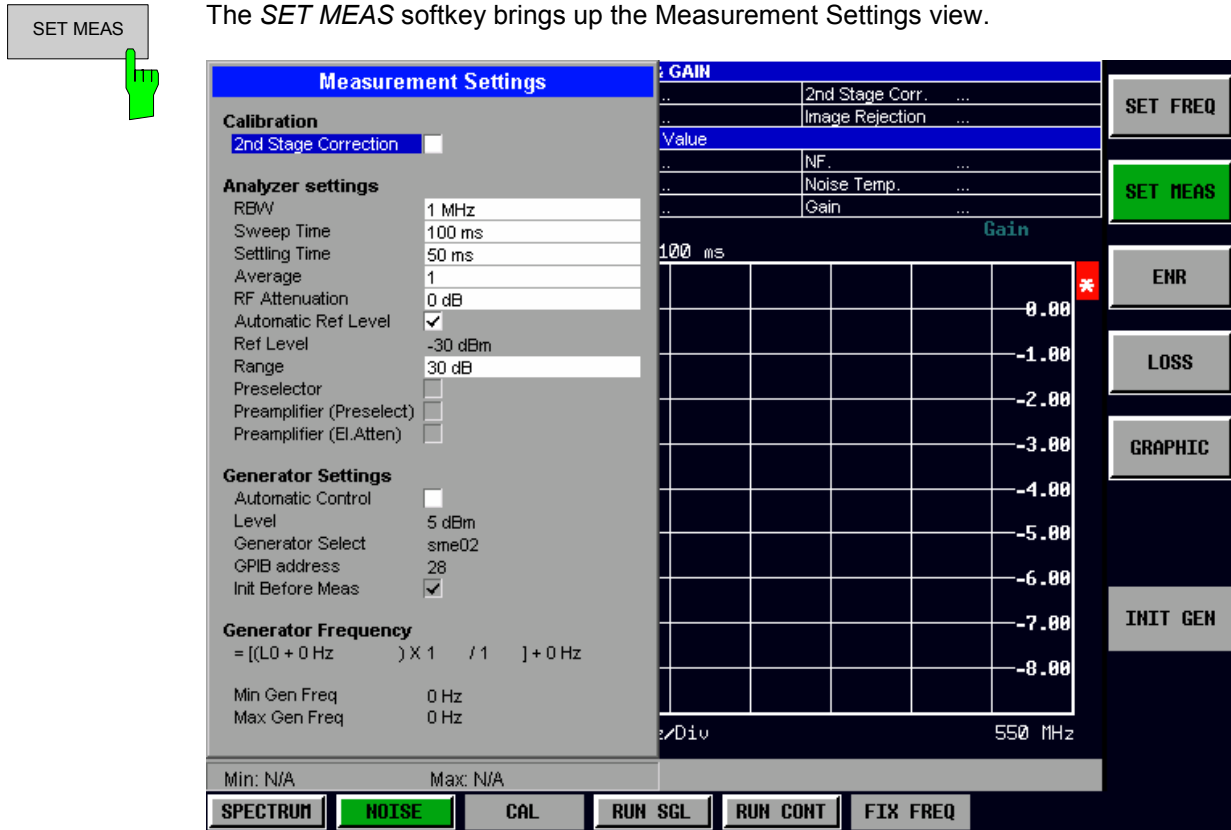

Fig. 2-9 Measurement Settings view

The parameters within the Measurement settings view are logically grouped together into:

- Calibration Settings
- Analyzer Settings
- Generator Settings
- Generator Frequency

Any parameters that are not available for editing will have a grey background. This usually occurs when one parameter setting makes another parameter invalid, for example if the *Control* of the Generator is *MANUAL* then none of the parameters below this (*Level*, *Generator Select*, *GPIO address*, *Init Before Meas*) have any meaning, so these parameters are greyed out.

When a particular parameter is selected within the Measurement Settings view the status bar changes to display information about the valid settings for the selected parameter.

Calibration

Calibration of the R&S FS-K30 application measures the noise introduced to a signal by the spectrum analyzer itself.

This can then be compensated for in measurements on a Device Under Test. This compensation is called 2nd Stage Correction, because the spectrum analyzer is the second stage of the test set-up, the DUT being the first stage.

The calibration process is described in detail in Section “Calibration”.

2nd Stage Correction

Calibration

2nd Stage Correction

The *2nd Stage Correction* setting is ON when calibration data is used to correct the measurement results for noise introduced by the spectrum analyser (the 2nd stage). When set to OFF, then no corrections are made to the measurement results.

When the *2nd Stage Correction* is switched off it is not possible to calibrate the option (the *CAL* hotkey is disabled)

The *2nd Stage Correction* setting can be turned OFF and ON without losing calibration data.

Analyzer Settings

The Analyzer settings are the general settings for the spectrum analyser concerning the level, attenuation and bandwidth of the signal to be measured.

RBW

Analyzer settings	
RBW	1 MHz
Sweep Time	100 ms
Settling Time	50 ms
Average	1
RF Attenuation	0 dB
Automatic Ref Level	<input checked="" type="checkbox"/>
Ref Level	-30 dBm
Range	30 dB
Pre-selector	<input type="checkbox"/>
Pre-amplifier(Pre-select)	<input type="checkbox"/>
Pre-amplifier(El. Attn.)	<input type="checkbox"/>

RBW is the Resolution Bandwidth that the spectrum analyzer will use for the measurement. This is the bandwidth of the bandpass filter that controls the size of the frequency 'window' that R&S FS-K30 will 'see.'

A large value for *RBW* will considerably improve the averaging of the display and reduces the influence of external sources of interference, as well as giving the fastest possible measurement time.

A low *RBW* should only be used across a very small frequency range. For measurements at low frequencies, the *RBW* must be reduced to prevent the LO frequency of the analyser from invalidating the measurement. At receive frequencies of 100 kHz, the *RBW* must not exceed 10 kHz.

Sweep Time

Analyzer settings	
RBW	1 MHz
Sweep Time	100 ms
Settling Time	50 ms
Average	1
RF Attenuation	0 dB
Automatic Ref Level	<input checked="" type="checkbox"/>
Ref Level	-30 dBm
Range	30 dB
Pre-selector	<input type="checkbox"/>
Pre-amplifier(Pre-select)	<input type="checkbox"/>
Pre-amplifier(El. Attn.)	<input type="checkbox"/>

The *Sweep Time* is the time taken by the spectrum analyzer to perform one complete measurement sweep (measurement step). Note that two sweeps are performed for each measurement step (once for noise source on, once with noise source off).

For narrow bandwidths, the *Sweep Time* should be increased in order to give accurate measurement results

Settling Time

Analyzer settings	
RBW	1 MHz
Sweep Time	100 ms
Settling Time	50 ms
Average	1
RF Attenuation	0 dB
Automatic Ref Level	<input checked="" type="checkbox"/>
Ref Level	-30 dBm
Range	30 dB
Pre-selector	<input type="checkbox"/>
Pre-amplifier(Pre-select)	<input type="checkbox"/>
Pre-amplifier(El. Attn.)	<input type="checkbox"/>

The *Settling Time* is the time taken for the DUT to settle after a noise source has been turned on or off.

Most noise sources generate an interfering DC component in addition to the noise spectrum. When the noise source is switched on or off, low-frequency DUTs may require this *Settling Time* for coupling capacitors to be charged or discharged.

Average

Analyzer settings	
RBW	1 MHz
Sweep Time	100 ms
Settling Time	50 ms
Average	1
RF Attenuation	0 dB
Automatic Ref Level	<input checked="" type="checkbox"/>
Ref Level	-30 dBm
Range	30 dB
Pre-selector	<input type="checkbox"/>
Pre-amplifier(Pre-select)	<input type="checkbox"/>
Pre-amplifier(El. Attn.)	<input type="checkbox"/>

The *Average* setting is the number of measurement sweeps over which the average is taken to produce the displayed measurement results.

The higher the number of sweeps over which the *Average* is taken, the more accurate the measurement results will be and the more stable the display, but the measurement time will be significantly longer.

An *Average* value of 1 means that each displayed result is produced from one measurement sweep. This is sufficient for most cases.

RF Attenuation

Analyzer settings	
RBW	1 MHz
Sweep Time	100 ms
Settling Time	50 ms
Average	1
RF Attenuation	0 dB
Automatic Ref Level	<input checked="" type="checkbox"/>
Ref Level	-30 dBm
Range	30 dB
Pre-selector	<input type="checkbox"/>
Pre-amplifier(Pre-select)	<input type="checkbox"/>
Pre-amplifier(El. Attn.)	<input type="checkbox"/>

RF Attenuation is the attenuator setting that the spectrum analyzer will use for the measurement, that is the attenuation that will be applied to the RF signal received.

To obtain a low noise figure for the analyzer and hence more accurate noise measurements, 0 dB should be set. With high DUT power levels or for critical matching, a higher setting is also possible. A setting of 10 dB will give a much better VSWR of the analyzer, but will result in a worse noise figure (of the analyzer).

Automatic Ref Level

Analyzer settings	
RBW	1 MHz
Sweep Time	100 ms
Settling Time	50 ms
Average	1
RF Attenuation	0 dB
Automatic Ref Level	<input checked="" type="checkbox"/>
Ref Level	-30 dBm
Range	30 dB
Pre-selector	<input type="checkbox"/>
Pre-amplifier(Pre-select)	<input type="checkbox"/>
Pre-amplifier(El. Attn.)	<input type="checkbox"/>

Automatic Ref Level selects whether the reference level for measurements is measured automatically (ON) or entered manually by the user (OFF).

When *Automatic Ref Level* is set to ON, R&S FS-K30 will measure the reference level automatically. This happens at one of two times:

- If *2nd Stage Correction* is ON, then the reference level is determined and set at the start of the calibration measurement. Several measurements are performed at the first frequency test point and the reference level is calculated from these results taking into account the maximum gain of the DUT (*Range*). Then the rest of the calibration measurement is performed.
- If *2nd Stage Correction* is OFF, then the reference level is determined and set prior to each measurement. Several measurements are performed at the first frequency test point and the reference level is calculated from these results. The *Range* setting is not significant. Then the rest of the measurement is performed.

Setting *Auto Ref Level* OFF will reduce the total measurement time for a noise measurement, since no reference level measurement will be performed.

Ref Level

Analyzer settings	
RBW	1 MHz
Sweep Time	100 ms
Settling Time	50 ms
Average	1
RF Attenuation	0 dB
Automatic Ref Level	<input type="checkbox"/>
Ref Level	-30 dBm
Range	30 dB
Pre-selector	<input type="checkbox"/>
Pre-amplifier(Pre-select)	<input type="checkbox"/>
Pre-amplifier(EI. Attn.)	<input type="checkbox"/>

Ref Level is the reference level that the spectrum analyzer will use for the measurement. All measurements are taken relative to this absolute reference level.

The *Ref Level* cannot be edited when *Automatic Ref Level* is set to ON, since this means that a measurement will be run to automatically determine the reference level. Refer to the *Automatic Ref Level* parameter description for details.

The *Ref Level* should be about 5 to 15dB above the noise display that occurs with the DUT connected and the noise source activated.

Even in the case of DUTs with a high-ripple frequency response, it can be useful to enter the *Ref Level* manually, as an automatic reference level setting may not always result in optimal settings.

Range

Analyzer settings	
RBW	1 MHz
Sweep Time	100 ms
Settling Time	50 ms
Average	1
RF Attenuation	0 dB
Automatic Ref Level	<input checked="" type="checkbox"/>
Ref Level	-30 dBm
Range	30 dB
Pre-selector	<input type="checkbox"/>
Pre-amplifier(Pre-select)	<input type="checkbox"/>
Pre-amplifier(EI. Attn.)	<input type="checkbox"/>

Range is the range of the DUT, that is, the maximum gain expected from the DUT.

This value is used when *Auto Ref Level* is ON and *2nd Stage Correction* is ON, to ensure that the expected power of the measured signal will be within the optimum operating range of the spectrum analyzer (the *Ref Level* is adjusted depending upon the *Range* value).

To ensure accurate measurement results, the *Range* parameter should not exceed the actual gain of the DUT by more than a margin of 10 dB.

Pre-selector

Analyzer settings	
RBW	1 MHz
Sweep Time	100 ms
Settling Time	50 ms
Average	1
RF Attenuation	0 dB
Automatic Ref Level	<input checked="" type="checkbox"/>
Ref Level	-30 dBm
Range	30 dB
Pre-selector	<input type="checkbox"/>
Pre-amplifier(Pre-select)	<input type="checkbox"/>
Pre-amplifier(EI. Attn.)	<input type="checkbox"/>

Pre-selector is used to turn on the pre-selector when option B2 is installed.

If the B2 option is not installed, then the *Pre-selector* field is not selectable.

The *Pre-selector* provides a pre-amplifier that may be used when it has been turned on using this parameter

Note that if both B2 and B25 options are installed only one pre-amplifier may be switched on. In this case the setting of this parameter determines which of the Pre-amplifiers may be switched on:

Pre-selector ON - Pre-amplifier for the pre-selector may be switched on.

Pre-selector OFF- Pre-amplifier for the electronic attenuator may be switched on.

Pre-amplifier (Pre-select)

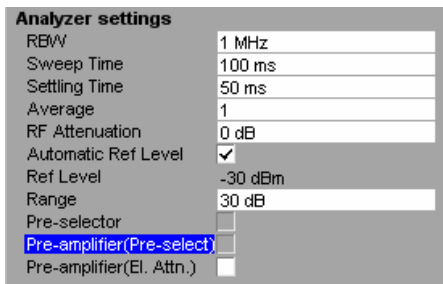

Pre-amplifier (Pre-Select) is used to turn on the pre-amplifier in the B2 pre-selector option.

Pre-amplifier (Pre-Select) is only available when B2 is installed and switched on using the *Pre-selector* setting.

Pre-amplifier (Electronic Attenuator)

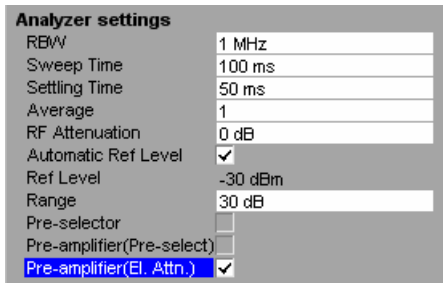

Pre-amplifier (EI.Attn.) is used to turn on the pre-amplifier in the B25 option.

Pre-amplifier (EI.Attn.) is only available when the B25 electronic attenuator option is installed. Additionally if the B2 option is also installed this parameter is only selectable when the *Pre-selector* field is switched OFF

Generator Settings

R&S FS-K30 can be used to control an external signal generator in order to generate a Local Oscillator (LO) frequency for noise measurements on frequency-converting DUTs. This applies for the *Measurement Modes*:

- Fixed IF, LO = RF + IF
- Fixed IF, LO = abs(RF – IF)
- Fixed LO, IF = RF + LO
- Fixed LO, IF = abs(RF – LO)

The *Measurement Mode* can be selected in the Frequency Settings view by pressing the *SET FREQ* softkey.

The Generator Settings group of parameters controls the set-up of this external signal generator.

Automatic Control

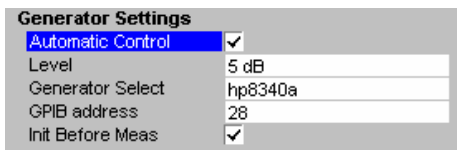

Automatic Control defines whether R&S FS-K30 controls the signal generator via GPIB commands (ON) or whether the signal generator is controlled by the user (OFF).

When *Automatic Control* is set to OFF, no GPIB commands will be issued to the signal generator. R&S FS-K30 will assume that the user sets up the signal generator correctly. None of the other parameters in the Generator Settings group will be available for editing when *Automatic Control* is set to OFF.

The Manual setting only really makes sense when the *Measurement Mode* is one of the Fixed LO cases in which the signal generator settings do not need to change during the measurement. In the Fixed IF *Measurement Modes*, meaningful results will only be possible if *Automatic Control* is set to ON, since R&S FS-K30 will expect the LO frequency to

be automatically tuned to the test *RF* frequency.

When *Automatic Control* is set to ON, R&S FS-K30 will issue GPIB commands during measurement execution in order to control the signal generator.

Note that option B10 must be installed on the spectrum analyzer for GPIB control of an external signal generator to be possible. When B10 is not installed, the *Automatic Control* parameter will be set to OFF and will not be selectable.

Level

Generator Settings	
Automatic Control	<input checked="" type="checkbox"/>
Level	5 dB
Generator Select	hp8340a
GPIB address	28
Init Before Meas	<input checked="" type="checkbox"/>

Level is the desired output power level of the external signal generator.

This parameter is only available when *Automatic Control* is set to ON. This parameter is not displayed when the B10 option is not installed

Generator Select

Generator Settings	
Automatic Control	<input checked="" type="checkbox"/>
Level	5 dB
Generator Select	hp8340a
GPIB address	28
Init Before Meas	<input checked="" type="checkbox"/>

Generator Select is used to select an external signal generator model from the defined list. This is necessary to ensure that the correct GPIB commands are sent to the signal generator.

The list of signal generators is defined within the spectrum analyzer software – refer to the spectrum analyzer and B10 option user manuals for details on how to edit this list and add new signal generators.

This parameter is only available when *Automatic Control* is set to ON. This parameter is not displayed when the B10 option is not installed

GPIB Address

Generator Settings	
Automatic Control	<input checked="" type="checkbox"/>
Level	5 dB
Generator Select	hp8340a
GPIB address	28
Init Before Meas	<input checked="" type="checkbox"/>

GPIB Address is the address used to control the external signal generator via GPIB.

This parameter is only available when *Automatic Control* is set to ON. This parameter is not displayed when the B10 option is not installed

Init before meas

Generator Settings	
Automatic Control	<input checked="" type="checkbox"/>
Level	5 dB
Generator Select	hp8340a
GPIB address	28
Init Before Meas	<input checked="" type="checkbox"/>

Init Before Meas is used to specify whether the external signal generator is initialised before each measurement or not.

When *Init Before Meas* is set to On, an initialisation sequence of GPIB commands will be sent to the signal generator before each measurement. This ensures that the signal generator will be in the correct state to receive control commands during measurement execution. However, this will add a time overhead to the overall measurement completion.

When *Init Before Meas* is set to Off, no initialisation sequence of GPIB commands will be sent to the signal generator when a measurement is run.

Note: The INIT GEN softkey in the main measurement results

view and measurements settings view can be pressed to get R&S FS-K30 to send the initialisation sequence of GPIB commands to the signal generator at any time.

This parameter is only available when *Automatic Control* is set to ON. This parameter is not displayed when the B10 option is not installed

Generator Frequency

When an external signal generator (or VCO) is used to create a Local Oscillator (LO) frequency, the following formula is used to calculate the generator frequency:

$$\text{Generator Frequency} = [(LO + \text{Offset 1}) * \text{Factor 1} / \text{Factor 2}] + \text{Offset 2}$$

The fields in the calculation can be edited directly. As the calculation is updated the minimum and maximum generator frequencies required based on the values in the calculation and the minimum and maximum LO frequencies are calculated and displayed.

Generator Frequency
= [(LO + 0 Hz) X 1 / 1] + 0 Hz

Min Gen Freq	0 Hz
Max Gen Freq	0 Hz

ENR Settings

This section of the user manual describes the ENR (Excess Noise Ratio) Settings view where the ENR values of the noise source can be modified.

It is essential for R&S FS-K30 to know the correct ENR values for the noise source in order to perform accurate measurements. The ENR values are used to calculate the effective noise temperature of the noise source and this is used during calculation of measurement results.

The manufacturer of the noise source supplies ENR values for it.

The *ENR* softkey brings up the ENR Settings view.

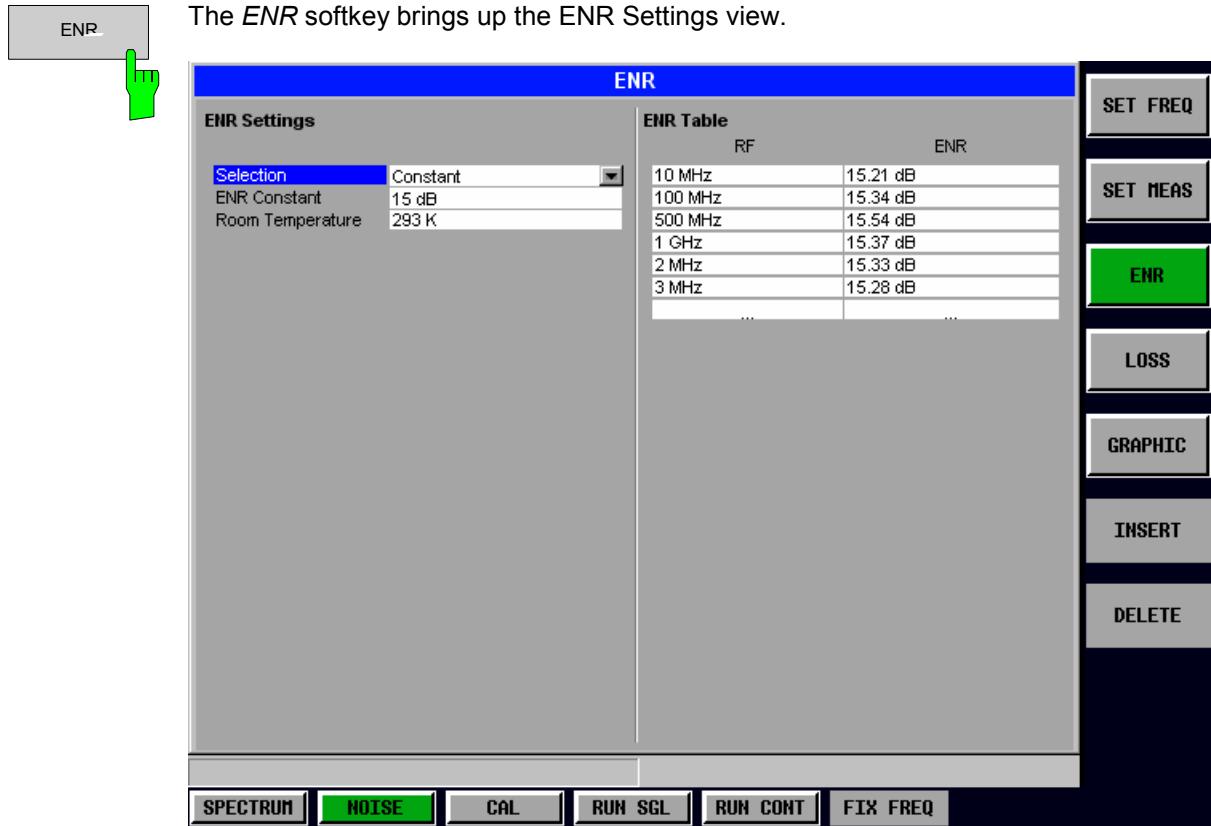

Fig. 2-10: ENR Settings view

The ENR settings are logically grouped together into:

- Main ENR settings on the left
- ENR table list on the right

When a particular parameter is selected within the ENR Settings view the status bar changes to display information about the valid settings for the selected parameter.

ENR Settings

The main settings are those that affect the overall use of ENR values during calculations.

Selection

Selection	Constant
ENR Constant	15 dB
Room Temperature	293 K

Selection should be set to Constant if one ENR value is to be used for all frequencies. In this case, the *ENR Constant* value will be used across the entire frequency range and the ENR List will be ignored.

When *Selection* is set to Table, R&S FS-K30 will use the Table of ENR values on the right of the view to calculate the ENR value to be used for each specific *RF* frequency at which a measurement is performed. The *ENR Constant* value will be ignored and will not be selectable.

ENR Constant

Selection	Constant
ENR Constant	15 dB
Room Temperature	293 K

ENR Constant is the constant ENR value of the noise source that is to be used across the entire frequency range.

This parameter is only available when *Selection* is set to Constant.

Room Temperature

Selection	Constant
ENR Constant	15 dB
Room Temperature	293 K

Room Temperature is the current room temperature as an absolute value in Kelvin. This is used in the calculation of the noise results.

ENR Table

The *ENR table* lists the ENR values of the noise source for different Receive Frequency (*RF*) values. The manufacturer of the noise source normally supplies this list of values. R&S FS-K30 will interpolate between points in the list for *RF* values used in a measurement that are not explicitly entered in the ENR table.

When focus is moved to the ENR table on the right of the view, navigation through the table is possible in all four directions using the cursor keys.

It is possible to add individual values directly into the ENR List, including insertion and deletion of *RF/ENR* value pairs (rows in the list). The list can contain up to 100 *RF/ENR* value pairs. Note that the order of *RF* values in the list is not important.

ENR tables can also be saved and recalled at any time by pressing the *FILES* hardkey. This allows specific ENR Lists to be saved for later use. Refer to section *Save/Recall* for details of how to use Save & Recall.

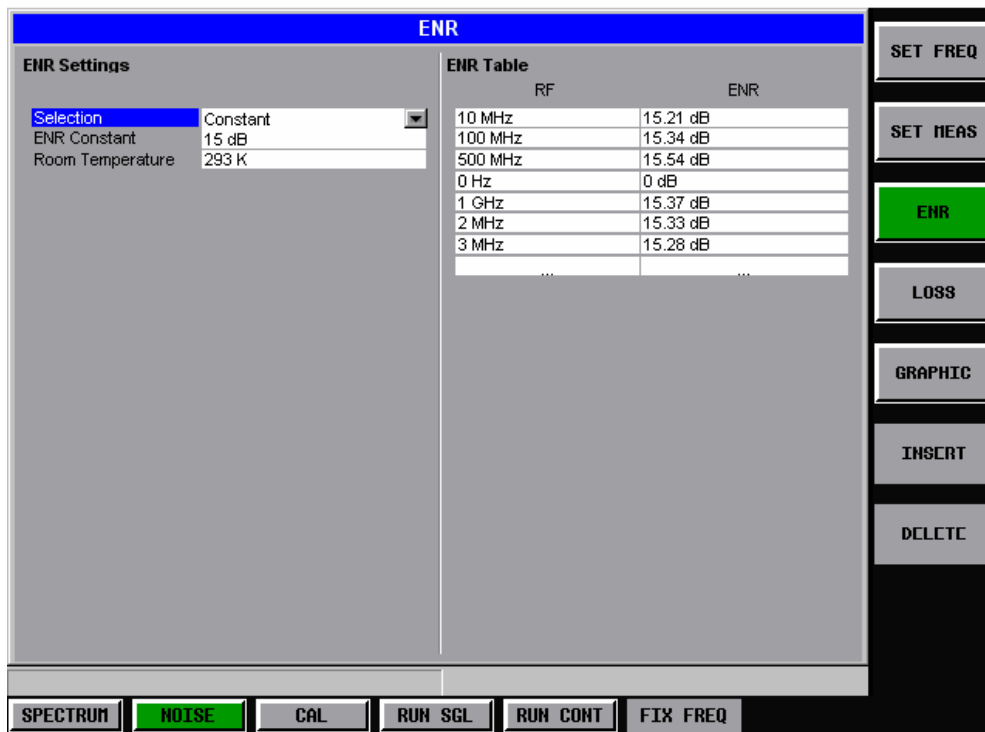
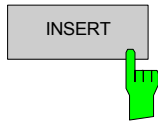

Fig. 2-11 ENR Table



The *INSERT* softkey inserts a new row in the ENR Settings table directly above the row currently selected. The new row will contain zero values. The cursor will be moved to the corresponding column in the new row ready for detailed entry.

The screenshot shows the 'ENR' settings screen. On the left, the 'ENR Settings' table is visible with the following data:

Selection	Constant
ENR Constant	15 dB
Room Temperature	293 K

On the right, the 'ENR Table' is shown with two columns: 'RF' and 'ENR'. The table contains the following data:

RF	ENR
10 MHz	15.21 dB
100 MHz	15.34 dB
500 MHz	15.54 dB
0 Hz	0 dB
1 GHz	15.37 dB
2 MHz	15.33 dB
3 MHz	15.28 dB

The '0 Hz' row is highlighted in blue. The screen also features a vertical toolbar on the right with buttons for 'SET FREQ', 'SET MEAS', 'ENR', 'LOSS', 'GRAPHIC', 'INSERT', and 'DELETE'. At the bottom, there is a horizontal toolbar with buttons for 'SPECTRUM', 'NOISE', 'CAL', 'RUN SGL', 'RUN CONT', and 'FIX FREQ'.

Fig. 2-12 Inserting ENR data

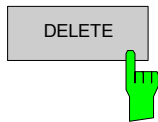

The *DELETE* softkey deletes the currently selected row in the ENR Settings table. Note that no confirmation is required for this action.

Loss Settings

This section of the user manual describes the Loss Settings view where the Loss values of the test setup can be modified.

The Loss settings allow additional losses due to cables or attenuators to be taken into consideration in measurement results. These additional losses are not taken into account in the calibration and therefore must be specified manually in order to achieve accurate results.

The **LOSS** softkey brings up the Loss Settings view.

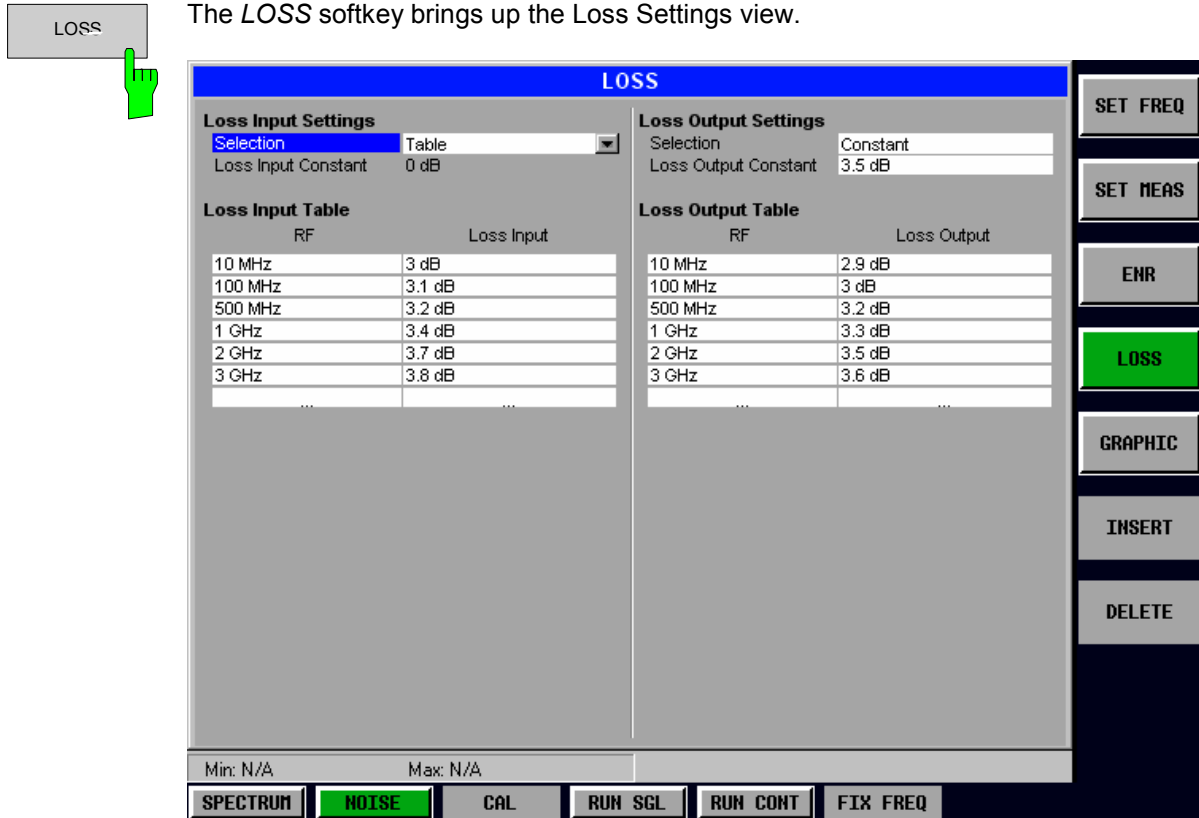

Fig. 2-13: Loss Settings view

The Loss settings are logically grouped together into:

1. The additional loss between the noise source and the DUT (Loss input)
2. The additional loss between the DUT and the analyzer (Loss output)

When a particular parameter is selected within the Loss Settings view the status bar changes to display information about the valid settings for the selected parameter.

Loss Settings – Loss Input Settings

The Loss Input settings are those that affect the overall use of Loss Input values during calculations.

Selection

Loss Input Settings	
Selection	Constant
Loss Input Constant	0 dB

Selection should be set to Constant if one Loss Input value is to be used for all frequencies. In this case, the *Loss Input Constant* value will be used across the entire frequency range and the Loss Input List will be ignored.

When *Selection* is set to Table, R&S FS-K30 will use the table of Loss Input values at the bottom left of the view to calculate the Loss Input value to be used for each specific *RF* frequency at which a measurement is performed. The *Loss Input Constant* value will be ignored and will not be selectable.

Loss Input Constant

Loss Input Settings	
Selection	Constant
Loss Input Constant	0 dB

Loss Input Constant is the constant Loss Input value that is to be used across the entire frequency range.

This parameter is only available when *Selection* is set to Constant.

Loss Input Table

The *Loss Input Table* lists the Loss Input values for different Receive Frequency (*RF*) values. R&S FS-K30 will interpolate between points in the list for *RF* values used in a measurement that are not explicitly entered in the Loss Input Settings list.

When focus is moved to the Loss Input table at the bottom left of the view, the current parameter in the table is highlighted. Navigation through the table is possible in all four directions using the cursor keys.

It is possible to add individual values directly into the Loss Input List, including insertion and deletion of *RF/Loss Input* value pairs (rows in the list). The list can contain up to 100 *RF/Loss Input* value pairs. Note that the order of *RF* values in the list is not important.

Loss Input tables can also be saved and recalled at any time by pressing the *FILES* hardkey. This allows specific Loss Input tables to be saved for later use. Refer to section “*Save/Recall*” for details of how to use Save & Recall.

LOSS

Loss Input Settings
 Selection: Constant
 Loss Input Constant: 0 dB

Loss Output Settings
 Selection: Constant
 Loss Output Constant: 0 dB

Loss Input Table

RF	Loss Input
10 MHz	3 dB
100 MHz	3.1 dB
500 MHz	3.2 dB
1 GHz	3.4 dB
2 GHz	3.7 dB
3 GHz	3.8 dB
...	...

Loss Output Table

RF	Loss Output
10 MHz	2.9 dB
100 MHz	3 dB
500 MHz	3.2 dB
1 MHz	3.3 dB
2 MHz	3.5 dB
3 MHz	3.6 dB
...	...

Min: 0 Hz Max: 7 GHz

SPECTRUM NOISE CAL RUN SGL RUN CONT FIX FREQ

SET FREQ
SET MEAS
ENR
LOSS
GRAPHIC
INSERT
DELETE

Fig. 2-14 Loss Input table

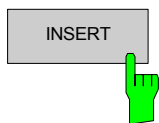

The *INSERT* softkey inserts a new row in the Loss Input Table directly above the row currently selected. The new row will contain zero values. The cursor will be moved to the corresponding column in the new row ready for detailed entry. The *INSERT* softkey is disabled when the maximum number of entries in the Loss Input Table has been reached.

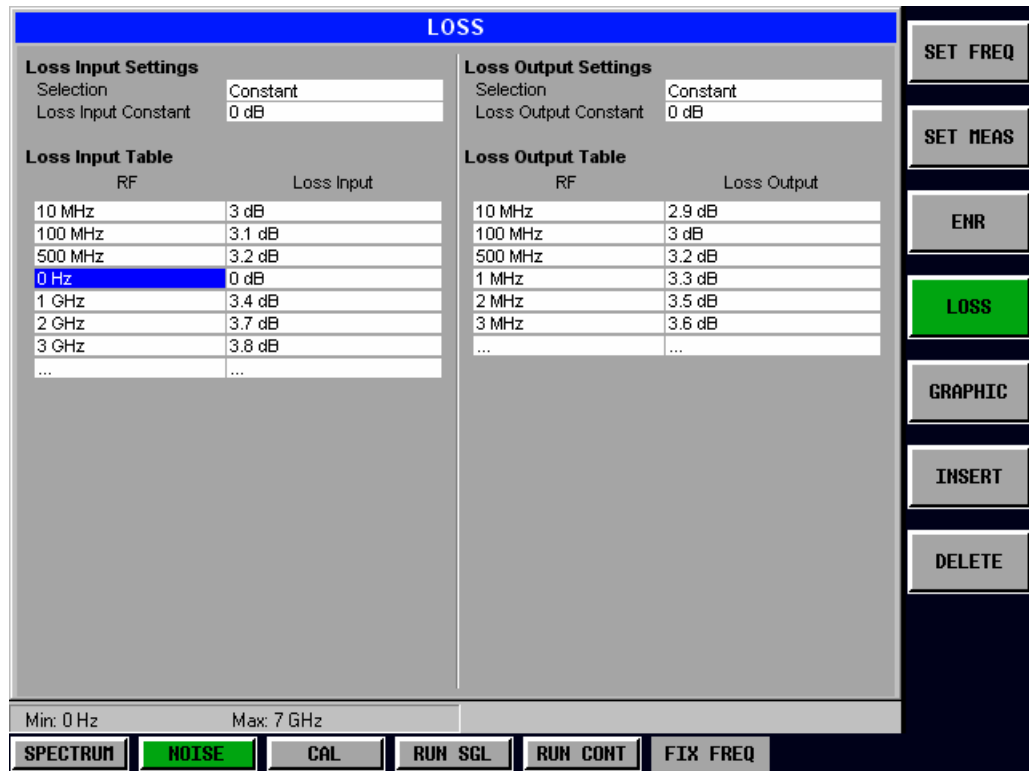
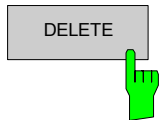

Fig. 2-15 Inserting data in the Loss Input table



The *DELETE* softkey deletes the currently selected row in the Loss Input Table. Note that no confirmation is required for this action.

Loss Settings – Loss Output Settings

The Loss Output settings are those that affect the overall use of Loss Output values during calculations.

Selection

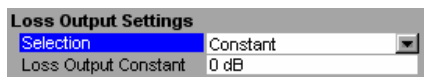

Selection should be set to Constant if one Loss Output value is to be used for all frequencies. In this case, the *Loss Output Constant* value will be used across the entire frequency range and the Loss Output Table will be ignored.

When *Selection* is set to Table, R&S FS-K30 will use the table of Loss Output values at the bottom right of the view to calculate the Loss Output value to be used for each specific *RF* frequency at which a measurement is performed. The *Loss Output Constant* value will be ignored and will not be selectable.

Loss Output Constant

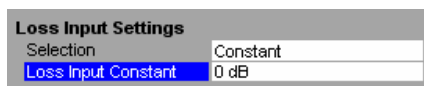

Loss Output Constant is the constant Loss Output value that is to be used across the entire frequency range. This parameter is only available when *Selection* is set to Constant.

Loss Output Table

The *Loss Output Table* lists the Loss Output values for different Receive Frequency (*RF*) values. R&S FS-K30 will interpolate between points in the list for *RF* values used in a measurement that are not explicitly entered in the Loss Output table.

When focus is moved to the Loss Output table at the bottom right of the view, the current parameter in the table is highlighted. Navigation through the table is possible in all four directions using the cursor keys.

It is possible to add individual values directly into the Loss Output Table, including insertion and deletion of *RF/Loss Output* value pairs (rows in the list). The list can contain up to 100 *RF/Loss Output* value pairs. Note that the order of *RF* values in the list is not important.

Loss Output tables can also be saved and recalled at any time by pressing the *FILES* hardkey. This allows specific Loss Output Lists to be saved for later use. Refer to section “*Save/Recall*” for details of how to use Save & Recall.

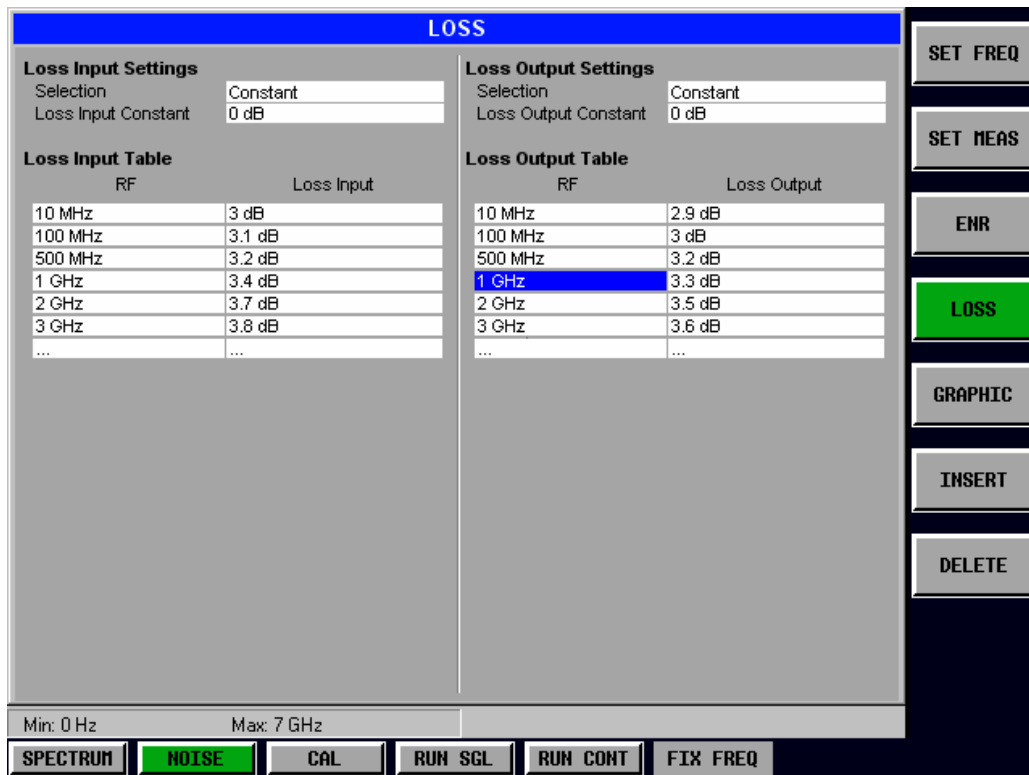
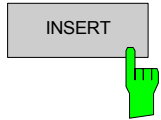

Fig. 2-16 Loss Output table



The *INSERT* softkey inserts a new row in the Loss Output Table directly above the row currently selected. The new row will contain zero values. The cursor will be moved to the corresponding column in the new row ready for detailed entry. The *INSERT* softkey shall be disabled when the maximum number of entries in the Loss Output Table has been reached

LOSS

Loss Input Settings
 Selection: Constant
 Loss Input Constant: 0 dB

Loss Output Settings
 Selection: Constant
 Loss Output Constant: 0 dB

Loss Input Table		Loss Output Table	
RF	Loss Input	RF	Loss Output
10 MHz	3 dB	10 MHz	2.9 dB
100 MHz	3.1 dB	100 MHz	3 dB
500 MHz	3.2 dB	500 MHz	3.2 dB
1 GHz	3.4 dB	0 Hz	0 dB
2 GHz	3.7 dB	1 GHz	3.3 dB
3 GHz	3.8 dB	2 GHz	3.5 dB
...	...	3 GHz	3.6 dB
	

Min: 0 Hz Max: 7 GHz

SPECTRUM NOISE CAL RUN SGL RUN CONT FIX FREQ

SET FREQ
 SET MEAS
 ENR
LOSS
 GRAPHIC
 INSERT
 DELETE

Fig. 2-17 Inserting data in the Loss Output table

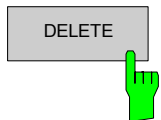

The *DELETE* softkey deletes the currently selected row in the Loss Output Table. Note that no confirmation is required for this action.

Graphic Settings

This section of the user manual describes the Graphic Settings view where all settings related to the graphical results display can be modified.

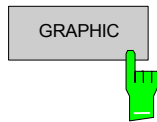

The *GRAPHIC* softkey brings up the Graphic Settings view.

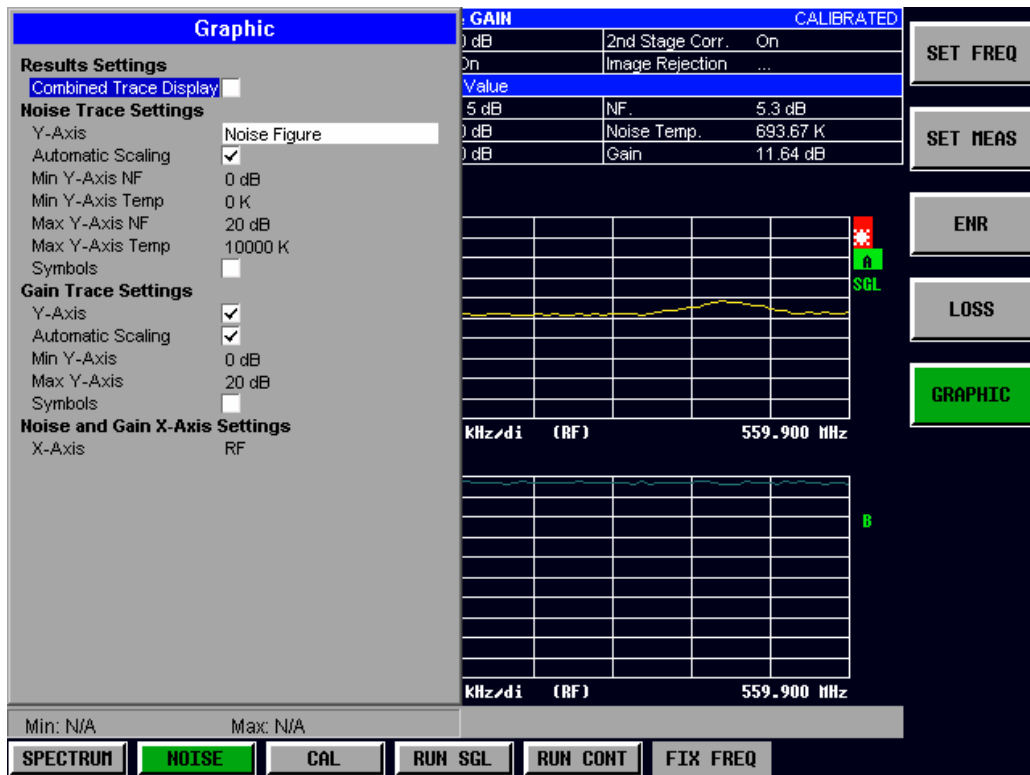

Fig. 2-18 Graphic Settings view

The parameters within the Graphic settings view are logically grouped together into:

- Results Settings. These are the settings that affect the overall results display
- Noise Trace Settings. These are the settings related to the graphical display of Noise results
- Gain Trace Settings. These are the settings related to the graphical display of Gain results
- Noise and Gain X-Axis Settings

Any parameters that are not available for editing will have a grey background. This usually occurs when one parameter setting makes another parameter invalid, for example if the *Automatic Scaling* of the Gain Trace Settings is switched on then the manual settings for the Y-Axis scaling (*Min Y-Axis*, *Max Y-Axis*, *Symbols*) have no meaning, so these parameters are greyed out.

When a particular parameter is selected within the Graphic Settings view the status bar changes to display information about the valid settings for the selected parameter.

Results Settings

The Results settings are those that affect the overall display of measurement results

Combined Trace Display



The *Combined Trace Display* setting specifies whether Noise and Gain results are to be displayed in the same Graph or within separate graphs.

When the *Combined Trace Display* is set to On, both Noise and Gain traces shall be displayed in the same Trace Display



Fig. 2-19 Combined Graphical Results

When the *Combined Trace Display* is set to Off, both Noise and Gain traces shall be displayed in the separate Trace Displays



Fig. 2-20 Separate Graphical Results

Noise Trace Settings

The Noise Trace settings are the specific settings associated with the graphical display of Noise (Noise Figure and Noise Temperature) results.

Y-Axis

Noise Trace Settings	
Y-Axis	Noise Figure
Automatic Scaling	<input checked="" type="checkbox"/>
Min Y-Axis NF	0 dB
Min Y-Axis Temp	0 K
Max Y-Axis NF	20 dB
Max Y-Axis Temp	10000 K
Symbols	<input type="checkbox"/>

The Y-Axis setting specifies what type of Noise result, if any, is to be displayed graphically.

The possible values for the Y-Axis settings are:

- Noise Figure
- Noise Temperature
- Off – Noise results are not displayed graphically

Automatic Scaling

Noise Trace Settings	
Y-Axis	Noise Figure
Automatic Scaling	<input checked="" type="checkbox"/>
Min Y-Axis NF	0 dB
Min Y-Axis Temp	0 K
Max Y-Axis NF	20 dB
Max Y-Axis Temp	10000 K
Symbols	<input type="checkbox"/>

The *Automatic Scaling* setting allows the automatic scaling of the noise results Y-Axis to be switched On and Off.

When the *Automatic Scaling* setting is set to On then the Noise results display shall be automatically scaled with regard to the Y-axis. The automatic scaling algorithm provides the optimal display of the complete range of results.

When the *Automatic Scaling* setting is set to Off then the scale for the Y-axis of noise results has to be specified manually.

Min Y-Axis NF

Noise Trace Settings	
Y-Axis	Noise Figure
Automatic Scaling	<input type="checkbox"/>
Min Y-Axis NF	0 dB
Min Y-Axis Temp	0 K
Max Y-Axis NF	20 dB
Max Y-Axis Temp	10000 K
Symbols	<input type="checkbox"/>

The *Min Y-Axis NF* setting specifies the minimum noise figure result that can be displayed graphically. This value is used for scaling the Y-Axis when Automatic scaling is switched Off and the Y-Axis is set to Noise Figure

Min Y-Axis Temp

Noise Trace Settings	
Y-Axis	Noise Figure
Automatic Scaling	<input type="checkbox"/>
Min Y-Axis NF	0 dB
Min Y-Axis Temp	0 K
Max Y-Axis NF	20 dB
Max Y-Axis Temp	10000 K
Symbols	<input type="checkbox"/>

The *Min Y-Axis Temp* setting specifies the minimum noise temperature result that can be displayed graphically. This value is used for scaling the Y-Axis when Automatic scaling is switched Off and the Y-Axis is set to Noise Temperature

Max Y-Axis NF

Noise Trace Settings	
Y-Axis	Noise Figure
Automatic Scaling	<input type="checkbox"/>
Min Y-Axis NF	0 dB
Min Y-Axis Temp	0 K
Max Y-Axis NF	20 dB
Max Y-Axis Temp	10000 K
Symbols	<input type="checkbox"/>

The *Max Y-Axis NF* setting specifies the maximum noise figure result that can be displayed graphically. This value is used for scaling the Y-Axis when Automatic scaling is switched Off and the Y-Axis is set to Noise Figure

Max Y-Axis Temp

Noise Trace Settings	
Y-Axis	Noise Figure
Automatic Scaling	<input type="checkbox"/>
Min Y-Axis NF	0 dB
Min Y-Axis Temp	0 K
Max Y-Axis NF	20 dB
Max Y-Axis Temp	10000 K
Symbols	<input type="checkbox"/>

The *Max Y-Axis Temp* setting specifies the maximum noise temperature result that can be displayed graphically. This value is used for scaling the Y-Axis when Automatic scaling is switched Off and the Y-Axis is set to Noise Figure

Symbols

Noise Trace Settings	
Y-Axis	Noise Figure
Automatic Scaling	<input type="checkbox"/>
Min Y-Axis NF	0 dB
Min Y-Axis Temp	0 K
Max Y-Axis NF	20 dB
Max Y-Axis Temp	10000 K
Symbols	<input checked="" type="checkbox"/>

The Symbols field allows each measured Noise value displayed graphically to be marked by a symbol. Displaying symbols for results helps to distinguish result types when several traces are printed on a monochrome printer.

Gain Trace Settings

The Gain Trace settings are the specific settings associated with the graphical display of Gain results.

Y-Axis

Gain Trace Settings	
Y-Axis	<input checked="" type="checkbox"/>
Automatic Scaling	<input type="checkbox"/>
Min Y-Axis	0 dB
Max Y-Axis	20 dB
Symbols	<input type="checkbox"/>

The Y-Axis setting allows the graphical display of gain results to be turned on and off. When the Y-Axis setting is set to On then gain results shall be displayed graphically

Automatic Scaling

Gain Trace Settings	
Y-Axis	<input checked="" type="checkbox"/>
Automatic Scaling	<input checked="" type="checkbox"/>
Min Y-Axis	0 dB
Max Y-Axis	20 dB
Symbols	<input type="checkbox"/>

The *Automatic Scaling* setting allows the automatic scaling of the gain results Y-Axis to be switched On and Off. When the *Automatic Scaling* setting is set to On then the gain results display shall be automatically scaled with regard to the Y-axis. The automatic scaling algorithm provides the optimal display of the complete range of results.

When the *Automatic Scaling* setting is set to Off then the scale for the y-axis of gain results has to be specified manually.

Min Y-Axis

Gain Trace Settings	
Y-Axis	<input checked="" type="checkbox"/>
Automatic Scaling	<input type="checkbox"/>
Min Y-Axis	0 dB
Max Y-Axis	20 dB
Symbols	<input type="checkbox"/>

The *Min Y-Axis* setting specifies the minimum gain result that can be displayed graphically. This value is used for scaling the Y-Axis when Automatic scaling is switched Off and the Y-Axis is switched On

Max Y-Axis

Gain Trace Settings	
Y-Axis	<input checked="" type="checkbox"/>
Automatic Scaling	<input type="checkbox"/>
Min Y-Axis	0 dB
Max Y-Axis	20 dB
Symbols	<input type="checkbox"/>

The *Max Y-Axis* setting specifies the maximum gain result that can be displayed graphically. This value is used for scaling the Y-Axis when Automatic scaling is switched Off and the Y-Axis is switched On

Symbols

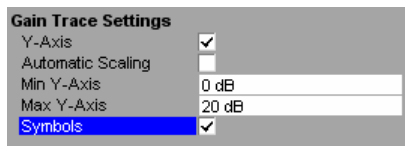

The Symbols field allows each measured gain value displayed graphically to be marked by a symbol. Displaying symbols for results helps to distinguish result types when several traces are printed on a monochrome printer.

Noise and Gain X-Axis Settings

X-Axis



The X-Axis setting allows user to configure the x-axis to the RF or IF frequencies. This setting is only available when the measurement mode is other than DIRECT.

Measurements in Detail

This section provides a more detailed explanation of the measurements provided by R&S FS-K30 and provides help for using R&S FS-K30 to measure the characteristics of specific types of DUT.

DUTs with Very Large Gain

If the gain of the DUT exceeds 60 dB, the total gain must be reduced by an external attenuator. The total gain of the DUT together with the external attenuator should lie within the range 10 dB to 60 dB. A total gain of 20 dB to 30 dB is recommended. For a DUT with a gain of e.g. 64 dB, it is recommended to use an external 40-dB attenuator.

If an external attenuator is used the entry in the *Range* field in the Measurement Settings view should be modified according to the total gain ($= G_{\text{dut}} - \text{external attenuator}$).

The attenuation values of the external attenuator are entered in the *LOSS OUTPUT* settings in the Loss Settings view.

Inaccuracies when entering this attenuation mainly influence the measured gain. The noise figure remains to a large extent unaffected.

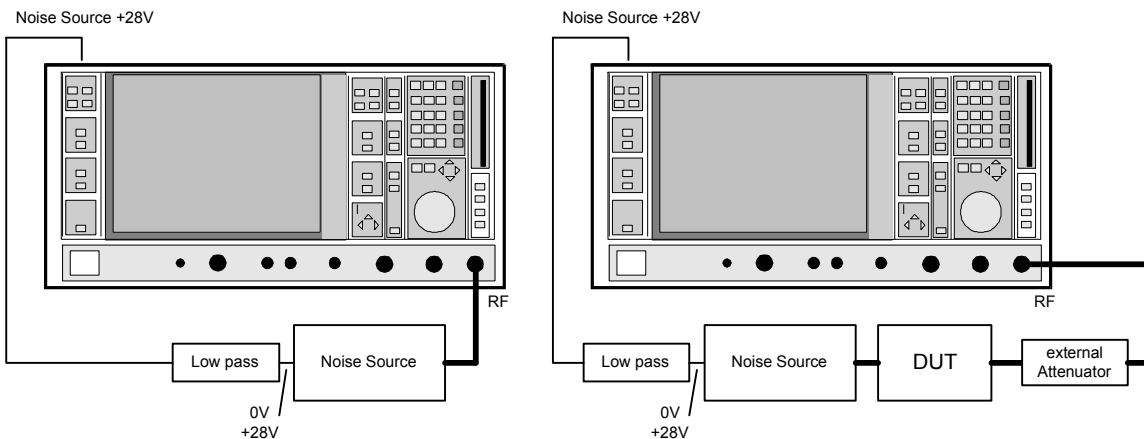

Fig. 2-1 Calibration and measurement on DUTs with a high gain

Frequency-converting Measurement

The frequency-converting measurement is used for DUTs that have an output frequency that differs from the input frequency, e.g. mixers and satellite converters. The converting measurement allows many variations, which differ from each other in two criteria:

- Fixed local oscillator frequency or fixed intermediate frequency with tracking LO frequency
- Rejection of image frequency (SSB, DSB)

Fixed LO and Fixed IF measurements

If a converting DUT with a fixed intermediate frequency is to be measured, R&S FS-K30 must be configured to vary the associated local oscillator in its frequency. This generator is controlled via the IEC bus. The required settings are made in the *Measurement Settings* view. One of the following settings for the *Mode* parameter in the *Frequency Settings* view must be selected in the case of the fixed intermediate frequency measurements:

fix IF LO=RF+IF

fix IF LO=abs(RF-IF)

For measurements of a DUT with fixed LO frequency, control of an external signal generator by R&S FS-K30 is not absolutely necessary. One of the following settings for the *Mode* parameter in the *Frequency Settings* view must be selected in the case of the fixed local oscillator frequency measurements:

fix LO IF=RF+LO

fix LO IF=abs(RF-LO)

Image-frequency Rejection (SSB, DSB)

Frequency-converting DUTs often do not only convert the desired input frequency but also the image frequency. A broadband noise source offers noise to the DUT not only at the input frequency but also at the image frequency. If the noise power at the IF gate is measured, the origin of the noise can no longer be determined. It may have been converted both from the input and from the image frequency range.

Example: IF = 100 MHz; LO-Freq. = 500 MHz; input frequency: 400 MHz; image frequency: 600 MHz

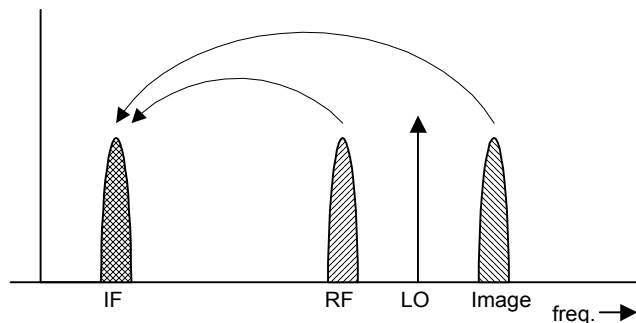

If a DUT, which equally converts the useful signal and the image to the IF frequency, is measured using the conventional Y-factor method or with the setting *2nd stage correction ON*, a measuring error of 3 dB will be produced. The noise figure is displayed 3 dB lower and the gain 3 dB higher. The following examples help to configure the test setup such that the actual values can be measured.

Measurement on a single-sideband mixer

IF 100 MHz; LO-Freq. 500 MHz; RF 400 MHz;

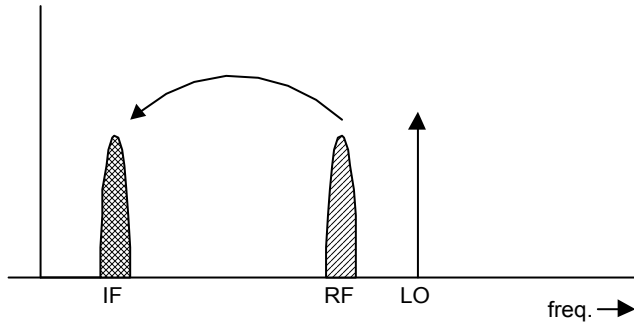

In general, a single-sideband mixer with a very high image rejection causes very few problems. The measurement is analogous to an amplifier. In this case set the *Image Rejection* parameter in the Frequency Settings view to a large value (e.g. 999.99dB)

Measurement on a mixer without sideband suppression

IF: 100 MHz; LO-Freq.: 500 MHz; RF: 400 MHz; Image-Freq.: 600 MHz

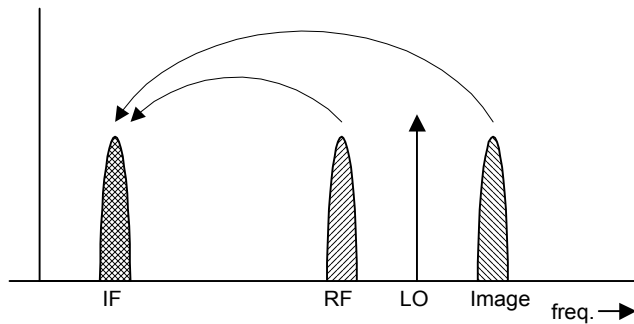

If the input and image frequencies are converted with the same application, an error of 3 dB occurs in the measurement results if the image rejection is not taken into account. In this case set the *Image Rejection* parameter in the Frequency Settings view to a small value (e.g. 0.0 dB)

Measurements on a mixer with an average sideband suppression

IF: 100 MHz; LO-Freq.: 500 MHz; RF: 400 MHz; Image-Freq.: 600 MHz

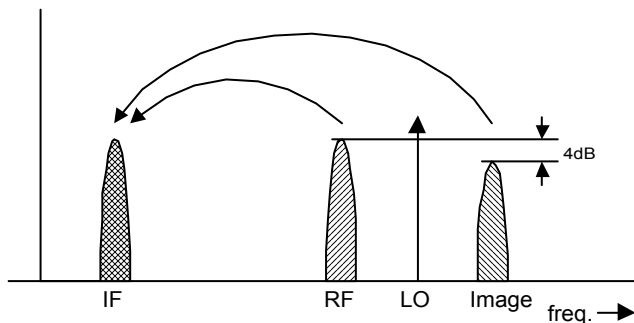

For measurements on a mixer with a low image-frequency rejection, a measuring error of 0 to 3 dB will be obtained if the image-frequency rejection is not taken into account. For the above example setting the *Image Rejection* parameter in the Frequency Settings view to 4 dB will produce the correct results

Measurements on a mixer with unknown sideband suppression

IF: 100 MHz; LO-Freq.: 500 MHz; RF: 400 MHz; Image-Freq.: 600 MHz

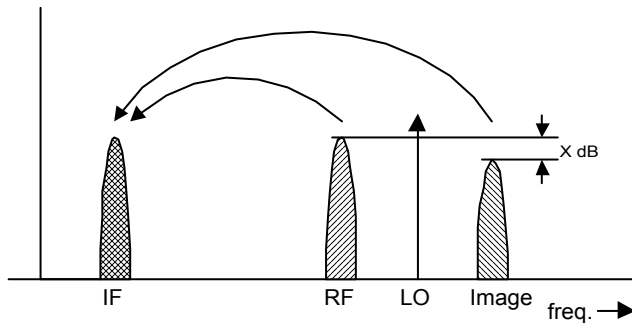

If the image rejection is not known, R&S FS-K30 can still be used to produce accurate noise results. However, the gain of the DUT must be known and an additional filter is required.

Noise Source Off

Noise Source off

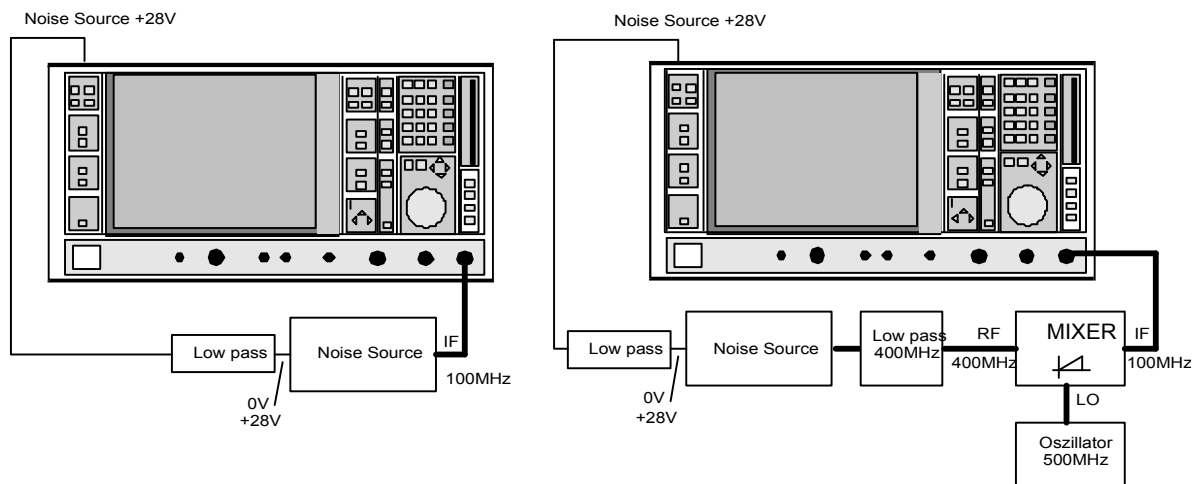

In this test setup, a lowpass prevents noise from the noise source from being fed in at the image frequency. Depending on the position of the frequency bands, a highpass or bandpass may also be necessary for the RF frequency instead of the lowpass. The important point is that noise from the noise source is not converted by a further receive path of the mixer. The noise of the noise source at the receive frequency must not be reduced. The insertion loss must be considered, if applicable.

With this test setup, the measurement on a mixer without sideband suppression corresponds to the measurement on a single-sideband mixer, and as setting the *Image Rejection* parameter in the Frequency Settings view to a large value (e.g. 999.99dB) will produce accurate results.

If the characteristics of the filter are to be taken into account, the insertion loss of the filter at the RF frequency can be entered in the *Loss Settings* view. If the actual filter suppression at the image frequency is to be considered as well, do not enter 999 dB but the actual attenuation in the *Image Rejection* parameter.

Measurements on a harmonics mixer

For a harmonics mixer, the input signals are not only converted to the IF by the wanted harmonic, but also by the harmonic of the LO signal produced in the mixer. In many cases, the mixer even features a lower conversion loss in the case of unwanted harmonics. For measurements on this type of mixer a bandpass filter must be used to make sure that there is only noise at the desired input frequency at the input of the DUT. This measurement is similar to measurements on a mixer with an average sideband suppression.

3 Remote Control

Description of commands

This section specifies all the remote control commands specific to the R&S FS-K30 option. Only those commands provided for this option are specified. For details of remote control commands provided by the host analyzer please refer to the analyzer user manual.

Notation

In the following sections, all commands implemented in the instrument are first listed in tables and then described in detail, arranged according to the command subsystems. The notation is adapted to the SCPI standard. The SCPI conformity information is included in the individual description of the commands.

Table of Commands

Command:	In the command column, the table provides an overview of the commands and their hierarchical arrangement (see indentations).
Parameter:	The parameter column indicates the requested parameters together with their specified range.
Unit:	The unit column indicates the basic unit of the physical parameters.
Comment:	In the comment column an indication is made on: <ul style="list-style-type: none"> – whether the command does not have a query form, – whether the command has only one query form – whether the command is implemented only with a certain option of the instrument

Indentations

The different levels of the SCPI command hierarchy are represented in the table by means of indentations to the right. The lower the level, the further the indentation to the right. Please note that the complete notation of the command always includes the higher levels as well.

Example: `SENSe:FREQuency:CENTer` is represented in the table as follows:

<code>SENSe</code>	first level
<code> :FREQuency</code>	second level
<code> :CENTer</code>	third level

Individual description

The individual description contains the complete notation of the command. An example for each command, the *RST value and the SCPI information are included as well.

Upper/lower case notation

Upper/lower case letters are used to mark the long or short form of the key words of a command in the description (see Section 3.5.2). The instrument itself does not distinguish between upper and lower case letters.

Special characters |

A selection of key words with an identical effect exists for several commands. These keywords are indicated in the same line; they are separated by a vertical stroke. Only one of these keywords needs to be included in the header of the command. The effect of the command is independent of which of the keywords is used.

Example: `SENSe:FREQuency:CW|:FIXed`

The two following commands with identical meaning can be created. They set the frequency of the fixed frequency signal to 1kHz:

SENSe:FREQuency:CW 1E3 = SENSe:FREQuency:FIXed 1E3

A vertical stroke in parameter indications marks alternative possibilities in the sense of "or". The effect of the command is different, depending on which parameter is used.

Example: Selection of the parameters for the command

DISPlay:FORMat FULL | SPLit

If parameter FULL is selected, full screen is displayed, in the case of SPLit, split screen is displayed.

- [] Key words in square brackets can be omitted when composing the header (cf. Section 3.5.2, Optional Keywords). The full command length must be accepted by the instrument for reasons of compatibility with the SCPI standards. Parameters in square brackets can be incorporated optionally in the command or omitted as well.
- { } Parameters in braces can be incorporated optionally in the command, either not at all, once or several times.

Description of parameters

Due to the standardisation, the parameter section of SCPI commands consists always of the same syntactical elements. SCPI has therefore specified a series of definitions, which are used in the tables of commands. In the tables, these established definitions are indicated in angled brackets (<...>) and will be briefly explained in the following (see also Section 3.5.5, "Parameters").

<Boolean> This keyword refers to parameters which can adopt two states, "on" and "off". The "off" state may either be indicated by the keyword **OFF** or by the numeric value 0, the "on" state is indicated by **ON** or any numeric value other than zero. Parameter queries are always returned the numeric value 0 or 1.

<numeric_value>

<num> These keywords mark parameters which may be entered as numeric values or be set using specific keywords (character data). The following keywords given below are permitted:

MINimum This keyword sets the parameter to the smallest possible value.

MAXimum This keyword sets the parameter to the largest possible value.

DEFault This keyword is used to reset the parameter to its default value.

UP This keyword increments the parameter value.

DOWN This keyword decrements the parameter value.

The numeric values associated to MAXimum/MINimum/DEFault can be queried by adding the corresponding keywords to the command. They must be entered following the quotation mark.

Example: SENSe:FREQuency:CENTer? MAXimum

returns the maximum possible numeric value of the center frequency as result.

<arbitrary block program data>

This keyword is provided for commands the parameters of which consist of a binary data block.

ABORt Subsystem

The ABORt subsystem provide a mechanism by which running measurements can be aborted

COMMAND	PARAMETERS	UNIT	COMMENT
:ABORt			no query

ABORt

Causes the current measurement being performed to be aborted.

Example: "ABOR" The R&S FS-K30 option will attempt to abort the current active measurement.

Characteristics: *RST value: -
SCPI: conforming

CALCulate: Subsystem

CALCulate:LIMit Subsystem

The CALCulate:LIMit subsystem consists of the limit lines and the corresponding limit checks. The limit lines can be defined as upper or lower limit lines. The individual Y values of the limit lines correspond to the values of the X-axis (CONTRol). The number of X- and Y-values must be identical.

Up to 6 limit lines can be defined at the same time (marked by LIMIT1 to LIMIT6) in the screen. Each limit line can be assigned a name. An explanatory comment can also be given for each

Example

Definition and use of a new limit line 5 for trace in the Noise Figure trace screen with the following features:

- upper limit line
- 5 ref. values: 126 MHz/-40 dB, 127 MHz/-40 dB, 128 MHz/-20 dB, 129 MHz/-40 dB, 130 MHz/-40 dB

Definition of the line:

1. Defining the name: `CALC:LIM5:NAME 'TEST1'`
2. Entering the comment: `CALC:LIM5:COMM 'Upper limit line'`
3. Associated trace in screen A: `CALC:LIM5:TRAC NFIG`
4. Defining the X-axis values: `CALC:LIM5:CONT 126MHZ, 127MHZ, 128MHZ, 129 MHZ, 130MHZ`
5. Defining the y values: `CALC:LIM5:UPP -40, -40, -30, -40, -40`

The definition of the safety margin and shifting in X- and/or Y-direction can take place as from here (see commands below).

Switching on and evaluating the line

1. Switching on the line `CALC:LIM5:UPP:STAT ON`
2. Switching on the limit `CALC:LIM5:STAT ON`
3. Starting a new measurement with synchronization: `INIT;*WAI`
4. Querying the limit check result: `CALC:LIM5:FAIL?`

COMMAND	PARAMETERS	UNIT	COMMENT
:CALCulate			
:LIMit<1 to 6> :TRACe :STATe :FAIL? :CLEAr [:IMMEdiate] :COMMeNt :COpy :NAME :DELeTe	NFIGure TEFFective GAIN <Boolean> -- <string> 1 to 8 < name> <string> --		Query only

CALCulate:LIMit<1 to 6>:TRACe NFIGure | TEFFective | GAIN

This command assigns a limit line to a particular measurement type. Measurement types include noise figure, noise temperature or gain.

NFIGure = Noise Figure results
TEFFective = Noise Temperature results
GAIN = Gain results

Examples: "CALC:LIM2:TRAC NFIG" Assigns limit line 2 to the noise figure measurement.
"CALC:LIM3:TRAC GAIN" Assigns limit line 3 to trace the gain measurement.

Characteristics: *RST value: -
SCPI: device-specific

CALCulate:LIMit<1 to 6>:STATe ON | OFF

This command switches on or off the limit check for the selected limit.

The result of the limit check can be queried with CALCulate:LIMit<1 to 6>:FAIL?.

Example: "CALC:LIM:STAT ON" Switches on the limit check for limit line 1
"CALC:LIM:STAT OFF" Switches off the limit check for limit line 1

Characteristics: *RST value: -
SCPI: conforming

CALCulate:LIMit<1 to 6>:FAIL?

This command queries the result of the limit check of the indicated limit line. It should be noted that a complete sweep must have been performed for obtaining a valid result. A synchronization with *OPC, *OPC? or *WAI should therefore be provided. The result of the limit check responds with 0 for PASS and 1 for FAIL.

Example: "INIT; *WAI" Starts a new measurement and waits for its end.
CALC:LIM3:FAIL? Queries the result of the check for limit line 3.

Characteristics: *RST value: -
SCPI: conforming

CALCulate:LIMit<1 to 6>:CLEar: [:IMMEDIATE]

This command deletes the result of the current limit check for all limit lines. After this command has been issued the command CALCulate:LIMit<1 to 6>:FAIL? will return 0 until the next measurement has been run. This command also clears the STATus:QUESTionable:LIMit condition and event registers. Note this command does not effect the display of the limit check on the display for the appropriate limit line.

Example: "CALC:LIM:CLE" Deletes the result of the limit check for limit line 1

Characteristics: *RST value: -
SCPI: conforming

This command is an event and is therefore not assigned an *RST value.

CALCulate:LIMit<1 to 6>:COMMeNt <string>

This command defines a comment for the limit line selected.

Example: "CALC:LIM5:COMM 'Upper limit for Gain'" Defines the comment for limit line 5.

Characteristics: *RST value: -
 SCPI: device-specific

CALCulate:LIMit<1 to 6>:COpy 1 to 6 | <name>

This command copies one limit line onto another one.

1 to 6 = number of the new limit line or:
name = name of the new limit line given as a string

Example: "CALC:LIM1:COpy 2" Copies limit line 1 to line 2.
 "CALC:LIM1:COpy 'NFIG2'" Copies limit line 1 to a new line named 'NFIG2'.

Characteristics: *RST value: -
 SCPI: device-specific

This command is an event and is therefore not assigned an *RST value and has no query.

CALCulate:LIMit<1 to 6>:NAME <name>

This command assigns a name to a limit line numbered 1 to 6. If it does not exist already, a limit line with this name is created.

name = name of the new limit line given as a string

Example: "CALC:LIM1:NAME 'NFIG1'" Assigns the name 'NFIG1' to limit line 1.

Characteristics: *RST value: 'REM1' to 'REM8' for lines 1 to 8
 SCPI: device-specific

CALCulate:LIMit<1 to 6>:DELeTe

This command deletes the selected limit line.

Example: "CALC:LIM1:DEL" Deletes limit line 1.

Characteristics: *RST value: -
 SCPI: device-specific

This command is an event and is therefore not assigned an *RST value and has no query.

CALCulate:LIMit:CONTrol Subsystem

The CALCulate:LIMit:CONTrol subsystem defines the x-axis (CONTrol-axis).

COMMAND	PARAMETERS	UNIT	COMMENT
:CALCulate			
:LIMit<1 to 6>			
:CONTrol			
[:DATA]	<numeric_value>	Hz	
	...		
:SHIFt	<numeric_value>	Hz	

CALCulate:LIMit<1 to 6>:CONTrol[:DATA] <numeric_value>,<numeric_value>

This command defines the X-axis values (frequencies) of the upper or lower limit lines. The number of values for the CONTrol axis and for the corresponding UPPer and/or LOWer limit lines have to be identical. Otherwise default values are entered for missing values or unnecessary values are deleted.

Example: "CALC:LIM2:CONT 1MHz,30MHz,100MHz, 300MHz,1GHz" Defines 5 reference values for the X-axis of limit line 2
 "CALC:LIM2:CONT?" Outputs the reference values for the X-axis of limit line 2 separated by a comma.

Characteristics: *RST value: -
 SCPI: conforming

CALCulate:LIMit<1 to 6>:CONTrol:SHIFt <numeric_value>

This command moves a limit line by the indicated value in x direction. The line is shifted by modifying the individual x values.

Example: "CALC:LIM2:CONT:SHIF 50KHZ" Shifts all reference values of limit line 2 by 50 kHz.

Characteristics: *RST value: -
 SCPI: device-specific

This command is an event and is therefore not assigned an *RST value and has no query.

CALCulate:LIMit:LOWer Subsystem

The CALCulate:LIMit:LOWer subsystem defines the lower limit line. Note that if a set command is issued in this subsystem the limit line effected is automatically converted to a lower limit line.

COMMAND	PARAMETERS	UNIT	COMMENT
:CALCulate :LIMit<1 to 6> :LOWer [:DATA] :STATe :SHIFt	<numeric_value> ... <Boolean> <numeric_value>	dB K -- dB K	

CALCulate:LIMit<1 to 6>:LOWer[:DATA] <numeric_value>,<numeric_value>...

This command defines the values for the selected lower limit line. The number of values for the CONTROL axis and for the corresponding LOWER limit line has to be identical. Otherwise default values are entered for missing values or unnecessary values are deleted. If the measured values are smaller than the LOWER limit line, the limit check signals errors.

Example: "CALC:LIM2:LOW -30,-40,-10,-40,-30" Defines 5 lower limit values for limit line 2 in the preset unit.
 "CALC:LIM2:LOW?" Outputs the lower limit values of limit line 2 separated by a comma.

Characteristics: *RST value: -
 SCPI: conforming

CALCulate:LIMit<1 to 6>:LOWer:STATe ON | OFF

This command switches on or off the indicated limit line in the selected measurement window. The limit check is activated separately with CALC:LIM:STAT ON.

Example: "CALC:LIM4:LOW:STAT ON" Switches on limit line 4 (lower limit)
 "CALC:LIM4:LOW:STAT OFF" Switches off limit line 4 (lower limit)

Characteristics: *RST value: -
 SCPI: conforming

CALCulate:LIMit<1 to 6>:LOWer:SHIFt <numeric_value>

This command shifts a limit line by the indicated value in Y-direction. The line is shifted by modifying the individual y values

Example: "CALC:LIM3:LOW:SHIF 20DB" Shifts all Y values of limit line 3 by 20 dB.

Characteristics: *RST value: -
 SCPI: device-specific

This command is an event and is therefore not assigned an *RST value and has no query.

CALCulate:LIMit:UPPer Subsystem

The CALCulate:LIMit:UPPer subsystem defines the upper limit line. Note that if a set command is issued in this subsystem the limit line effected is automatically converted to an upper limit line.

COMMAND	PARAMETERS	UNIT	COMMENT
:CALCulate LIMit<1 to 6> :UPPer [:DATA]	<numeric_value> ... <Boolean>	DB K	
:STATe :SHIFt	<numeric_value>	DB K	

CALCulate:LIMit<1 to 6>:UPPer[:DATA] <numeric_value>,<numeric_value>...

This command defines the values for the upper limit lines independently of the measurement window. The number of values for the CONTrol axis and for the corresponding UPPer and/or LOWER limit line have to be identical. Otherwise default values are entered for missing values or unnecessary values are deleted. The unit must be identical with the unit selected by CALC : LIM : UNIT. If no unit is indicated, the unit defined with CALC : LIM : UNIT is automatically used.

Example: "CALC:LIM2:UPP -10,0,0,-10,-5" Defines 5 upper limit values for limit line 2 in the preset unit.

"CALC:LIM2:UPP?" Outputs the upper limit values for limit line 2 separated by a comma.

Characteristics: *RST value: -
SCPI: conforming

CALCulate:LIMit<1 to 6>:UPPer:STATe ON | OFF

This command switches on or off the indicated limit line. The limit check is activated separately with CALC:LIM:STAT ON

Example: "CALC:LIM4:UPP:STAT ON" Switches on limit line 4 (upper limit)

Characteristics: *RST value: -
SCPI: conforming

CALCulate:LIMit<1 to 6>:UPPer:SHIFt <numeric_value>

This command moves a limit line by the indicated value in Y-direction. The line is shifted by modifying the individual y values

Example: "CALC:LIM3:UPP:SHIF 20DB" Shifts all Y values of limit line 3 by 20 dB.

Characteristics: *RST value: -
SCPI: device-specific

This command is an event and is therefore not assigned an *RST value and has no query.

CALCulate:MARKer Subsystem

The CALCulate:MARKer subsystem checks the marker functions in the instrument.

COMMAND	PARAMETERS	UNIT	COMMENT
:CALCulate			
:MARKer			
[:STATe]	<Boolean>	--	No query
:AOFF			
:TRACe	NOISe GAIN	--	
:X	<numeric_value>	HZ	
:Y	--	--	Query only
:MAXimum			
[:PEAK]	--	--	No query
:MINimum			
[:PEAK]	--	--	No query

CALCulate:MARKer[:STATe] ON | OFF

This command switches on or off the marker 1 on the selected trace.

If the user switches off the trace (DISPlay:WINDow1:TRACe1 OFF) where the marker is on, the marker is switched off automatically. If the user then tries switching on the marker again, the marker is set to the active trace. If both noise and gain traces are off (DISPlay:WINDow1:TRACe1 OFF and DISPlay:WINDow1:TRACe2 OFF) marker can not be switched on.

Example: ALC:MARK ON Marker 1 is switched on.

CALCulate:MARKer:AOFF

This command switches off the marker1.

Example: CALC:MARK:AOFF Marker 1 is switched off.

CALCulate:MARKer:TRACe NOISe | GAIN

This command assigns the marker1 to the indicated trace.

Example: CALC:MARK:TRAC NOIS Assigns marker 1 to the Noise trace.

CALCulate:MARKer:X

This command positions the marker1 to the indicated frequency measurement point.

If the marker is off, it switches on the marker first.

Example: CALC:MARK:X 550 MHZ Positions marker 1 to frequency 550 MHz.

CALCulate:MARKer:Y

This command queries the measured value of marker 1. If the marker is off, it switches on the marker first.

To obtain a valid query result, a complete sweep with synchronization to the sweep end must be performed between the activation of the marker and the query of the y value.

The query result is output in the unit determined with the selected trace.

Example: CALC:MARK:Y? Outputs the measured value of marker 1.

CALCulate:MARKer:MAXimum[:PEAK]

This command positions the marker to the current maximum value of the corresponding trace. The marker 1 is activated first or switched to the marker mode.

Example: CALC:MARK:MAX Positions marker 1 to the maximum of the selected trace.

CALCulate:MARKer:MiNimum[:PEAK]

This command positions the marker to the current minimum value of the corresponding trace. The marker 1 is activated first or switched to the marker mode.

Example: CALC:MARK:MIN Positions marker 1 to the minimum of the selected trace.

CONFigure Subsystem

COMMAND	PARAMETERS	UNIT	COMMENT
:CONFigure			
ARRay			
MEMory<1...3>	ONCE	--	no query
:CORRection	--	--	no query
:LIST			
CONTInuous	--	--	no query
SINGle	--	--	no query
SINGle	--	--	no query

CONFigure:ARRay:MEMory<1 to 3> ONCE

This restamote control command copies the last recorded measurement results (Noise Figure, Noise Temperature and Noise Gain traces) into the selected memory.

Example: "CONF:ARR:MEM1 ONCE" Copies the last recorded measurement result into the memory1.

CONFigure:CORRection

This remote control command configures R&S FS-K30 for a second stage correction measurement. After this command has been executed the second stage correction measurement will be the measurement started when the user issues the INITiate command

Example: "CONF:CORR" R&S FS-K30 is configured to run second stage correction measure measurements.

Characteristics: *RST value: -
 SCPI: device-specific

This command is an event and is therefore not assigned an *RST value and has no query.

CONFigure:LIST:CONTInuous

This remote control command configures R&S FS-K30 for a continuous frequency list measurement. After this command has been executed a continuous frequency list measurement will be the measurement started when the user issues the INITiate command

Example: "CONF:LIST:CONT" R&S FS-K30 is configured to run continuous frequency list measurements.

Characteristics: *RST value: -
 SCPI: device-specific

This command is an event and is therefore not assigned an *RST value and has no query.

CONFigure:LIST:SINGle

This remote control command configures R&S FS-K30 for a single frequency list measurement. After this command has been executed a single frequency list measurement will be the measurement started when the user issues the INITiate command

Example: "CONF:LIST:SING" R&S FS-K30 is configured to run single frequency list measurements.

Characteristics: *RST value: -
 SCPI: device-specific

This command is an event and is therefore not assigned an *RST value and has no query.

CONFigure:SINGle

This remote control command configures R&S FS-K30 for a single frequency measurement. After this command has been executed a single frequency measurement will be the measurement started when the user issues the INITiate command

Example: “CONF:SING”- R&S FS-K30 is configured to run single frequency measurements.

Characteristics: *RST value: -
 SCPI: device-specific

This command is an event and is therefore not assigned an *RST value and has no query.

DISPlay Subsystem

The DISPlay subsystem controls the selection and presentation of textual and graphic information as well as of measurement data on the display.

COMMAND	PARAMETERS	UNIT	COMMENT
:DISPLAY			
:ARRay			
:MEMory<1...3>			
[:STATe]	<boolean>		
:CURRent			
:DATA			
[:STATe]:FORMat	<boolean>		
:DATA	SPLit SINGle		
:TRACe<1>			
[:WINDow<1>]	NFIGure TEFFective		
:TRACe<1 2>			
[:STATe]			
:SYMBols	<Boolean>		
:X	<Boolean>		
[:SCALe]			
:Y	RF IF		
[:SCALe]			
:AUTO			
:BOTTom	<Boolean>		
:RLEVel	<numeric_value>	DB K	
:AUTO	<numeric_value>	DBM	
:TOP	<Boolean>		
:TABLE	<numeric_value>	DB K	
	<Boolean>		

DISPlay:ARRay:MEMory<1 to 3>[:STATe]

This command switches on or off the display of the corresponding memory trace.

Example: DISP:ARR:MEM2 ON - Switches on the display of memory 2.

DISPlay:CURRent:DATA[:STATe] ON|OFF

This command switches on or off the display of the last recorded measurement trace.

Syntax: DISPlay:CURRent:DATA

Example: DISP:CURR:DATA OFF - The FS-K30 option will remove the current result traces from display.

DISPlay:FORMat SPLit | SINGle

This remote control command toggles the display of traces between being displayed in separate graphs or displayed in a single combined graph..

Example: “DISP:FORM SING” Sets the R&S FS-K30 display to full screen.

Characteristics: *RST value: GRAPH
SCPI: device-specific

DISPlay:DATA:TRACe<1> NFIGure | TEFFective

This remote control command allows the user to specify the type of data to be displayed in trace 1. The user can select either to display either Noise Figure results (NFIGure) or Noise temperature (TEFFective – to keep compatibility with the NFA). Note that Trace 1 is always noise results and Trace 2 is always for Gain results.

NFIGure = Noise Figure results
TEFFective = Noise Temperature

Example: "DISP:DATA:TRAC:NFIG" The R&S FS-K30 option will display noise figure results in trace 1.

Characteristics: *RST value: NFIGure
SCPI: device-specific

DISPlay[:WINDow<1>]:TRACe<1|2>[:STATe] ON | OFF

This command switches on or off the display of the corresponding trace and related information in the selected measurement window.

Example: "DISP:TRAC ON"- Switches on the display of trace 1 (Noise results).

Characteristics: *RST value: ON for both TRACe1 and TRACe2
SCPI: conforming

DISPlay[:WINDow<1>]:TRACe<1|2>:SYMBOLS ON | OFF

This command switches on or off the display of the symbols to mark the measurement points for the specified trace i.e. Noise or Gain.

This command will only have a noticeable effect if the required trace is active as set by the command DISP:WIND:TRAC<1|2>:STAT ON.

Example: "DISP:TRAC:SYMB ON" Switches on the display of symbols for trace 1 (Noise results)

Characteristics: *RST value: OFF for both TRACe1 and TRACe2
SCPI: device-specific

DISPlay[:WINDow<1>]:TRACe<1|2>:X[:SCALE] RF | IF

This command allows user to select RF or IF frequency to be displayed on the X axis when the DUT is not amplifier.

The numeric suffix TRACe<1 to 2> is irrelevant.

Example: "DISP:TRAC:X IF" IF frequency will be displayed on X axis.

DISPlay[:WINDow<1>]:TRACe<1|2>:Y[:SCALE]:AUTO ON | OFF

This command switches on or off automatic scaling of the Y-axis for the specified trace display. Automatic scaling set the Y-axis to automatically scale to best fit the measurement results.

Note that the specified trace must be active for this command to have an immediate effect. This can be achieved using the command DISP:WIND:TRAC<1|2>:STAT ON.

Example: "DISP:TRAC:Y:AUTO ON" Switches on automatic scaling of the Y-axis for all traces

Characteristics: *RST value: ON for both TRACe1 and TRACe2
SCPI: conforming

DISPlay[:WINDow<1>]:TRACe<1|2>:Y[:SCALe]:BOTTom <numeric_value>

This command sets the minimum (bottom) Y-axis display value for the specified trace display. Note that this command has no affect if automatic scaling of the Y-axis is enabled or the specified trace is not currently active.

Example: "DISP:TRAC:Y:BOTT -30" Sets the minimum Y-axis display to -30 dB for trace 1

Characteristics: *RST value: 0 dBm
SCPI: conforming

DISPlay[:WINDow<1>]:TRACe<1|2>:Y[:SCALe]:RLEVel <numeric_value>

This command sets the reference level for the Y-axis display value for all trace displays.

Example: "DISP:TRAC:Y:RLEV 0" Sets the reference level 0 dBm

Characteristics: *RST value: -30 dBm
SCPI: conforming

DISPlay[:WINDow<1>]:TRACe<1|2>:Y[:SCALe]:RLEVel:AUTO ON | OFF

This command enables or disables automatic reference level detection.

Example: "DISP:TRAC:Y:RLEV:AUTO ON" turns on automatic reference level detection.

Characteristics: *RST value: ON
SCPI: conforming

DISPlay[:WINDow<1>]:TRACe<1|2>:Y[:SCALe]:TOP <numeric_value>

This command sets the maximum (top) Y-axis display value for the specified trace display. Note that this command has no affect if automatic scaling of the Y-axis is enabled or the specified trace is not currently active.

Example: "DISP:TRAC:Y:TOP 30" Sets the maximum Y-axis display to 30 dB for trace 1

Characteristics: *RST value: 20 dB
SCPI: conforming

DISPlay[:WINDow<1>]:TABLe

This command toggles the display of results in graphical or tabular form.

Example: "DISP:WIND1:TABL ON" The R&S FS-K30 option will display the table of results

Characteristics: *RST value: OFF
SCPI: device-specific

FETCh Subsystem

The FETCh subsystem retrieves results for the most recently completed fixed frequency or frequency list measurements. Frequency list results are returned as a list of results where the result is that requested in the specific fetch command. Single frequency results are single numbers in the described units.

Note: *Corrected measurements are only accessible after a user calibration has been performed.*

COMMAND	PARAMETERS	UNIT	COMMENT
:FETCh			
:ARRAy			
MEMory<1...3>			
NOISe			
FIGure?	--		query only
TEMPerature?	--		query only
GAIN?	--		query only
:NOISe			
FIGure?	--		query only
TEMPerature?	--		query only
GAIN?	--		query only
:SCALar			
:NOISe			
FIGure?	--		query only
TEMPerature?	--		query only
GAIN?	--		query only

FETCh:ARRAy:MEMory<1to3>:NOISe:FIGure?

FETCh:ARRAy:MEMory<1to3>:NOISe:TEMPerature?

FETCh:ARRAy:MEMory<1to3>:NOISe:GAIN?

These remote control commands request the FS-K30 option to return the noise measurement results in the selected memory. The results will be returned as a 100 element array, either of noise figure, noise temperature or noise gain results.

Example: "FETC:ARR:MEM2:NOIS:GAIN?"

- The FS-K30 option will return an array of 100 gain results from memory 2.

FETCh:ARRAy:NOISe:FIGure?
FETCh:ARRAy:NOISe:TEMPerature?
FETCh:ARRAy:NOISe:GAIN?

These remote control commands request the R&S FS-K30 option to return the last recorded noise measurement results. The results will be returned as an array of up to 100 elements, either of noise figure, noise temperature or noise gain results.

The command will only return a result array if the y-axis measurement for the passed argument is currently active.

Noise gain measurements will be active if the remote control command
 DISP:WIND:TRAC:Y:SCAL:GAIN ON was previously entered.

Noise figure or temperature measurements will be active if the remote control command
 DISP:WIND:TRAC:Y:SCAL:NFIG ON or DISP:WIND:TRAC:Y:SCAL:NTEM ON was previously entered.

Example: "FETCh:ARRAy:NOIS:GAIN?" - The R&S FS-K30 option will return an array of 100 measured elements associated with the last noise gain measurement assuming the measurement is currently active.

Characteristics: *RST value: -
 SCPI: device specific

FETCh:SCALAr:NOISe:FIGure?
FETCh:SCALAr:NOISe:TEMPerature?
FETCh:SCALAr:NOISe:GAIN?

These remote control commands request the R&S FS-K30 option to return the last recorded noise measurement result for a single frequency measurement. The results will be a single noise figure, noise temperature or noise gain results.

Example: "FETC:SCAL:NOIS:GAIN?" The R&S FS-K30 option will return the last noise gain measurement obtained from a single frequency measurement.

Characteristics: *RST value: -
 SCPI: device specific

FORMAT Subsystem

The FORMat subsystem provide specifies the data format of the data transmitted from and to the instrument

COMMAND	PARAMETERS	UNIT	COMMENT
:FORMat [:DATA] :DEXPort :DSEParator	ASCIi REAL POINT COMMa		

FORMat[[:DATA] ASCIi | REAL"

This command specifies the data format for the data transmitted to from the instrument to the control PC.

The scpi commands, which returnfloats in binary format are:

FETCh:ARRAy:NOISe:FIGure?
 FETCh:ARRAy:NOISe:TEMPerature?
 FETCh:ARRAy:NOISe:GAIN?
 SENSE:FREQUency:LIST:DATA?

Example: "FORM:DATA REAL"

FORMat[[:DATA]:DEXPort:DSEParator POINT | COMMa"ß"POINT | COMMa

This command defines which decimal separator (decimal point or comma) is to be used for outputting measurement data to the file in ASCII format. Different languages of evaluation programs (eg MS-Excel) can thus be supported.

Example: "FORM:DATA:DEXP:DSEP COMM" - Sets the decimal point as comma

INITiate Subsystem

The INITiate subsystem configures the instrument prior to a measurement being carried out. It is basically used to tell the instrument which measurement is to be performed and takes any necessary step to set up the instrument for the measurement.

COMMAND	PARAMETERS	UNIT	COMMENT
INITiate [:IMMediate]			no query

INITiate[:IMMediate]

This remote control command requests the FS- K30 option to start a new measurement sequence. If a measurement sequence is already in progress, then the command will be ignored.

Example: "INIT" - The FS- K30 option will attempt to start a new measurement.

Characteristics: *RST value: -
SCPI: Conforming

INPut Subsystem

The INPut subsystem controls the input characteristics of the RF inputs of the instrument.

COMMAND	PARAMETERS	UNIT	COMMENT
:INPut			
:ATTenuation	<numeric_value>	DB	
:PRESelection [:STATe]	<Boolean>		Only with option B2
:GAIN :STATe	<Boolean>		Only with option B2 or B25

INPut:ATTenuation <numeric_value>

This remote control command specifies the RF attenuation that the analyser imposes.

Example: "INP:ATT 10"-attenuation of the analyzer is set to 10 dB.

Characteristics: *RST value: 0 dB
SCPI: conforming

INPut:PRESelection[:STATe] ON | OFF

This remote control command switches the preselection on or off.

Example: "INP:PRE:STAT ON" - preselection is switched on.

Characteristics: *RST value: OFF
SCPI: device-specific

The command is only available with the preselector option B2.

INPut:GAIN:STATe ON | OFF

This remote control command switches the pre-amplifier on and off. If only the B2 or B25 option is present then the pre-amplifier of the installed option is controlled. If both the B2 and B25 options are present then the pre-amplifier controlled by this command depends on the setting for the INPut:PRESelection[:STATe] command. If the INPut:PRESelection[:STATe] is set to ON then the pre-amplifier for the B2 option is controlled by this command, otherwise the pre-amplifier of the B25 option is controlled.

Example: "INP:GAIN:STAT ON" - switches the pre-amplifier

Characteristics: *RST value: OFF
SCPI: device-specific

The command is only available with the preselector option B2 or electronic attenuator option B25.

INSTrument Subsystem

COMMAND	PARAMETERS	UNIT	COMMENT
:INSTrument :SElect :NSElect	NOISe <numeric_value>		

INSTrument:SElect

This remote control command selects active operation of the R&S FS-K30 option by specifying its name.

Example: "INST:SEL NOIS" The R&S FS-K30 option will be selected as the active option.

Characteristics: *RST value: SANalyzer
 SCPI: conforming

INSTrument:NSElect

This remote control command selects active operation of the R&S FS-K30 option by specifying its associated option number.

Example: "INST:NSEL 19" The R&S FS-K30 option will be selected as the active option.

Characteristics: *RST value: 1
 SCPI: conforming

SENSe Subsystem

The SENSe command is used to set and get the values of parameters in the remote instrument. The get variant of the SENSe command differs from set in that it takes no parameter values (unless otherwise stated) but is followed by the character '?' and will return the parameter's value in the same format as it is set.

E.g. SENS:SWE:TIME 10MS – sets the sweep time to 10 milliseconds
 SENS:SWE:TIME? - response 0.01 - returns the current sweep time

The SENSe subsystem is divided into a number of subsystems. The main areas being, the commands used to control the equipment and measurement settings. The SENSe command will be divided into equipment settings, general measurement settings and specific measurement settings (one subsystem for each type of measurement).

Equipment Settings

The following diagram shows the Equipment Settings SENSe subsystem:

COMMAND	PARAMETERS	UNIT	COMMENT
[[:SENSe]			
:CORRection			
:ENR			
:MODE	SPOT TABLE		
:SPOT	<numeric_value>	DB	
[:MEASurement]			
:TABLE			
:DATA	<numeric_value>, <numeric_value> ...	Hz, DB	
:TEMPerature	<numeric_value>	K	
:LOSS			
:INPut			
:MODE	SPOT TABLE		
:SPOT	<numeric_value>	DB	
:TABLE	<numeric_value>, <numeric_value> ...	Hz, DB	
:OUTPut			
:MODE	SPOT TABLE		
:SPOT	<numeric_value>	DB	
:TABLE	<numeric_value>,<numeric_value> ...	Hz, DB	
:IREJection	<numeric_value>		
[:STATe]	<Boolean>	DB	

[SENSe]:CORRection:ENR:MODE TABLE | SPOT

The ENR mode selection remote control command is used to specify whether a single ENR spot value applies for all measured frequencies or whether an ENR list table is to be used (ENR values specified at specific input frequencies).

TABLE = Use the ENR table
SPOT = Use the constant ENR value

Example: "SENS:CORR:ENR:MODE SPOT"
The R&S FS-K30 option uses the currently configured constant ENR value specified for input frequencies.

Characteristics: *RST value: SPOT
SCPI: device specific

[SENSe]:CORRection:ENR:SPOT <numeric_value>

The ENR remote control command allows the ENR value applicable to the Noise source for all input frequencies to be specified. This value provides a simple mechanism to enter an ENR value that is applicable throughout a range of measurement frequencies.

Example: "SENS:CORR:ENR:SPOT 30"
The R&S FS-K30 option sets the internal constant ENR value to 30 dB for all measured input frequencies. This command will however not be effective if the remote control command SENS:CORR:ENR:MODE:TABL was previously entered.

Characteristics: *RST value: 15 dB
SCPI: device specific

[SENSe]:CORRection:ENR[:MEASurement]:TABLe:DATA <numeric_value>,<numeric_value>,...

This ENR remote control command allows an ENR lookup table list to be specified that will be used by the K30 option to determine the correct ENR (excess noise ratio) figure to use for the input frequency that requires measuring. The list arguments specified will completely overwrite all current ENR frequency list entries regardless of how many entries are present and how many entries are being supplied for the new list. This command will however not be effective if the remote control command SENS:CORR:ENR:MODE SPOT was previously entered.

numeric value := a frequency ENR pair of arguments, up to a maximum of argument 100 pairs. The frequency can be specified in Hz, kHz, MHz or GHz. The ENR figure must be a value in dB.

Example: "SENS:CORR:ENR:MEAS:TABL:DATA 1MHZ,10,2MHZ,12"
The R&S FS-K30 option will overwrite the current ENR list with the two entry pairs specified.

Characteristics: *RST value: -
SCPI: device specific

[SENSe]:CORRection:TEMPerature <numeric_value>

This ENR remote control command allows the room temperature of the operating environment to be specified. This value will be taken into account when calculating noise results.

Example: "SENS:CORR:TEMP 291.50"
The R&S FS-K30 option will factor in a room temperature of 291.50 Kelvin (18.5 C) when performing noise measurements.

Characteristics: *RST value: 293 K
SCPI: device specific

[SENSe]:CORRection:LOSS:INPut:MODE SPOT | TABLe

This remote control command is used to identify whether a single input loss value applies for all measured frequencies or whether an input loss list is to be used. (Loss Input values specified at specific input frequencies).

SPOT = The Constant loss input value for all measurement frequencies is used.
TABLe = The loss input table is used.

Example: "SENS:CORR:LOSS:INP:MODE SPOT"
The R&S FS-K30 option uses the currently configured loss input constant as the loss input value applicable for all input frequencies to be measured.

Characteristics: *RST value: SPOT
SCPI: device specific

[SENSe]:CORRection:LOSS:INPut:SPOT <numeric value>

This remote control command allows the loss input constant to be set to a value applicable for all input frequencies to be measured. This command provides a simple mechanism to enter a loss input value that is applicable throughout a range of measurement frequencies.

This command will however not be effective if the remote control command SENS:CORR:LOSS:INP:MODE TABL was previously entered.

Example: "SENS:CORR:LOSS:INP:SPOT 10"
The R&S FS-K30 option sets the internal input loss constant value to 10 dB for all measured input frequencies.

Characteristics: *RST value: 0 dB
SCPI: device specific

[SENSe]:CORRection:LOSS:INPut:TABLE <numeric value>,<numeric value>...

This remote control command allows a new user defined input loss lookup table list to be specified. The list arguments specified will completely overwrite all current input loss list entries regardless of how many entries are present and how many entries are being supplied for the new list. This list will be interpreted by the K30 option to determine the correct input loss to use for the frequency that requires measuring.

This command will however not be effective if the remote control command SENS:CORR:LOSS:INP:MODE SPOT was previously entered.

numeric_value = a frequency loss pair of arguments, in frequency loss order up to a maximum of argument 100 pairs. The frequency is option specific and can be specified in Hz, kHz, MHz or GHz with a maximum of two decimal places. The loss figure must be a value in dB between -999.99 and 999.99 accurate to two decimal places.

Example: “SENS:CORR:LOSS:INP:TABL 1MHz,10,2MHz,12”
The R&S FS-K30 option will overwrite the current internal loss input table with the two entry pairs specified.

Characteristics: *RST value: -
SCPI: device specific

[SENSe]:CORRection:LOSS:OUTPut:MODE SPOT | TABLE

This remote control command is used to identify whether a single output loss value applies for all measured frequencies or whether an output loss list is to be used. (Loss Output values specified at specific input frequencies).

SPOT = The Constant loss output value for all measurement frequencies is used.

TABLE = The loss output table is used.

Example: “SENS:CORR:LOSS:OUTP:MODE SPOT”
The R&S FS-K30 option uses the currently configured output loss constant as the output loss value applicable for all input frequencies to be measured.

Characteristics: *RST value: SPOT
SCPI: device specific

[SENSe]:CORRection:LOSS:OUTPut:SPOT <numeric value>

This remote control command allows the loss output constant to be set to a value applicable for all input frequencies to be measured. This command provides a simple mechanism to enter a loss output value that is applicable throughout a range of measurement frequencies.

Example: “SENS:CORR:LOSS:OUTP:SPOT 10”
The R&S FS-K30 option sets the internal output loss constant value to 10 dB for all measured input frequencies. This command will however not be effective if the remote control command SENS:CORR:LOSS:OUTP:TABL was previously entered.

Characteristics: *RST value: 0 dB
SCPI: device specific

[SENSe]:CORRection:LOSS:OUTPut:TABLE <numeric value>,<numeric value>...

This remote control command allows a new user defined output loss lookup table list to be specified. The list arguments specified will completely overwrite all current output loss list entries regardless of how many entries are present and how many entries are being supplied for the new list. This list will be interpreted by the K30 option to determine the correct output loss to use for the frequency that requires measuring.

This command will however not be effective if the remote control command `SENS:CORR:LOSS:OUTP:MODE SPOT` was previously entered.

numeric_value = a frequency loss pair of arguments, in frequency loss order up to a maximum of argument 100 pairs. The frequency can be specified in Hz, kHz, MHz or GHz with a maximum of two decimal places. The loss figure must be a value in dB accurate to two decimal places.

Example: `"SENS:CORR:LOSS:OUTP:TABL 1MHz,10,2MHz,12"`
The R&S FS-K30 option will overwrite the current internal loss output table with the two entry pairs specified.

Characteristics: *RST value: -
SCPI: device specific

[SENSe]:CORRection:IREJection <numeric value >

This remote control command allows an image rejection value associated with DUT to be entered which will be effective across the complete range of measurement frequencies.

Example: `"SENS:CORR:IREJ 100"` an image rejection value of 100 dB will be used.

Characteristics: *RST value: 999.99 dB
SCPI: device specific

[SENSe]:CORRection[:STATe] ON | OFF

This remote control command can be used to control whether the R&S FS-K30 option will factor in the results obtained from second stage correction when performing a noise and gain measurement.

Example: `"SENS:CORR:STAT ON"` The R&S FS-K30 option will take into account the calibration results when performing the noise and gain measurement.

Characteristics: *RST value: OFF
SCPI: device specific

Measurement Settings

The following diagram shows the Measurement Settings SENSE subsystem:

COMMAND	PARAMETERS	UNIT	COMMENT
[[:SENSE]			
:BANDwidth			
[:RESolution]	<numeric_value>	Hz	
:BWIDth			
[:RESolution]	<numeric_value>	Hz	
:SWEep			
:TIME	<numeric_value>	S	
:COUnT	<numeric_value>	--	
:FREQuency:	<numeric_value>	Hz	
:CW	<numeric_value>	Hz	
:FIXed	<numeric_value>	Hz	Same as the previous command
:LIST			
:DATA	<numeric_value>, <numeric_value>, <numeric_value>	Hz, Hz, Hz	
	...		
:START	<numeric_value>	Hz	
:STOP	<numeric_value>	Hz	
:STEP	<numeric_value>	Hz	
:CONFigure			
:MODE:			
:SYSTem			
:LOSCillator	FIXed VARiable		
:FREQuency	<numeric_value>	Hz	
:IF			
:FREQuency	<numeric_value>	Hz	
:DUT	AMPLifier DOWNconv UPConv		

[SENSE]:BANDwidth|BWIDth:RESolution <numeric value>

This remote control allows the resolution bandwidth of the analyser to be specified.

Example: "SENS:BAND:RES 1MHZ" The R&S FS-K30 option will set the resolution bandwidth to 1 MHz.

Characteristics: *RST value: 1 MHz
SCPI: conforming

[SENSE]:SWEep:TIME <numeric value>

This remote control command allows the sweep time to be specified.

Example: "SENS:SWE:TIME 100MS" sets sweep time to 100 milliseconds.

Characteristics: *RST value: 100 milliseconds
SCPI: conforming

[SENSe]:SWEep:COUNT <numeric value>

This remote control specifies the number of sweeps over which the measurement results are to be averaged. The higher the number of sweeps averaged the more accurate the results however the more sweeps required the longer the measurement takes to perform.

Example: "SENS:SWE:COUN 10" sets the averaging of the measurement to be performed over 10 sweeps

Characteristics: *RST value: 1
 SCPI: conforming

[SENSe]:FREQuency:START <numeric value>

This remote control command can be used to specify the starting frequency for a new frequency measurement list that requires computing. This value will form the basis of one of the input criteria for computing a new frequency list.

Example: "SENS:FREQ:START 500MHZ" the starting frequency for a new list, yet to be created, is set to a value of 500 MHz.

Characteristics: *RST value: 550 MHz
 SCPI: conforming

[SENSe]:FREQuency:STOP <numeric value>

This remote control command can be used to specify the ending frequency for a new frequency measurement list that requires computing. This value will form the basis of one of the input criteria for computing a new frequency list.

Example: "SENS:FREQ:STOP 700MHZ" the ending frequency for a new list, yet to be created, is set to a value of 700 MHz.

Characteristics: *RST value: 560 MHz
 SCPI: conforming

[SENSe]:FREQuency:STEP <numeric value>

This remote control command can be used to specify the step frequency for a new frequency measurement list that requires computing. This value will form the basis of one of the input criteria for computing a new frequency list.

Example: "SENS:FREQ:STEP 10MHZ" the step frequency for a new list, yet to be created, is set to a value of 10 MHz.

Characteristics: *RST value: 2 MHz
 SCPI: device-specific

[SENSe]:FREQUENCY[:CW]:FIXed <numeric value>

This remote control command is used to specify a single fixed frequency to measure noise and gain continuously. The value specified with this command is only used when a single frequency measurement is initiated.

Example: “SENS:FREQ 10MHz” the noise measurement is to be made continuously at a fixed frequency of 10 MHz.

Characteristics: *RST value: 550 MHz
SCPI: conforming

[SENSe]:FREQUENCY:LIST:DATA <numeric value>,<numeric value>,<numeric value>...

This remote control command allows a new frequency list to be specified which will be used to perform noise and gain measurements. Each list entry will pertain to three separate frequency entities, a RF frequency, a local oscillator frequency and an intermediate frequency. The list arguments specified will completely overwrite all the current frequency list entries regardless of how many entries are present and how many entries are being supplied for the new list. The new list supplied will remain as the active list until such time that a new list is automatically created. If the frequency list mode is set to DIRECT then the LO and IF frequencies specified in this command are ignored, and the query version of this command returns 0's for these parameters in this case.

The values specified in this command are not used if a single frequency measurement is initiated .
numeric_value = a user defined set of three frequency measurements arguments up to a maximum of 100 entry triplets in the following order. Fixed frequency, local oscillator frequency and Intermediate frequency. The allowable frequency range is option dependent, specified in either in Hz, kHz, MHz and GHz and will be accurate to 2 decimal places for Hz input.

Example: “SENS:FREQ:LIST:DATA 550MHz,300MHz,900MHz”
a one entry frequency list will be created with a fixed frequency of 550 MHz, a local oscillator frequency of 300 and an intermediate frequency of 900MHz.

Characteristics: *RST value: 550 MHz
SCPI: device-specific

[SENSe]:CONF:MODE:SYSTEM:LOSCillator FIXed | VARiable

This remote control command can be used to specify whether the local oscillator will be used as a fixed frequency source or a variable frequency source.

The command will not have any immediate effect if a direct frequency list is being used which is set by the remote control command SENS:CONF:MODE:DUT AMPL.

See the remote command SENS:CONF:MODE:DUT for an explanation on how the measurement lists are created.

FIXed = Local Oscillator is used as a fixed frequency source
VARiable = Local Oscillator is used as a variable frequency source

Example: “SENS:CONF:MODE:SYST:LOSC FIX” the local oscillator will be set to a fixed frequency.

Characteristics: *RST value: - (SENS:CONF:MODE:DUT AMPL)
SCPI: device-specific

[SENSe]:CONFigure:MODE:SYSTem:LOSCillator:FREQUENCY <numeric value>

This remote control command can be used to specify a fixed local oscillator frequency for a new frequency measurement list that requires computing. This value will form the basis of one of the input criteria for computing a new frequency list.

The command will not have any immediate effect if a direct frequency list is being used (which is set by the SENS:CONF:MODE:DUT AMPL command) or a variable local oscillator frequency has been specified (which is set by the SENS:CONF:MODE:SYST:LOSC VAR comand) .

Example: “SENS:CONF:MODE:SYST:LOSC:FREQ 1MHZ”
the fixed local oscillator frequency for a new list, yet to be created, is set to a value of 1 MHz.

Characteristics: *RST value: - 0 Hz
SCPI: device-specific

[SENSe]:CONFigure:MODE:SYSTem:IF:FREQUENCY <numeric value>

This remote control command can be used to specify a fixed intermediate frequency for a new frequency measurement list that requires computing. This value will form the basis of one of the input criteria for computing a new frequency list.

The command will not have any immediate effect if a direct frequency list is being used (which is set by the SENS:CONF:MODE:DUT AMPL command) or a variable intermediate frequency has been specified (which is set by the SENS:CONF:MODE:SYST:LOSC FIX comand) .

Example: “SENS:CONF:MODE:SYST:IF:FREQ 500KHZ”
the fixed intermediate frequency for a new list, yet to be created, is set to a value of 500 kHz.

Characteristics: *RST value: - 0 Hz
SCPI: device-specific

[SENSe]:CONFigure:MODE:DUT AMPLifier | DOWNc | UPConv

This remote control command allows the type of DUT to be defined. This setting will determine the method that will be used to create the frequency measurement list. This command in addition to SENS:CONF:MODE:SYST:LOSC will determine how the DUT is tested. Fixed Local Oscillator or fixed Intermediate Frequencies will be taken from the settings supplied by SENS:CONF:MODE:SYST:LOSC:FREQ and SENS:CONF:MODE:SYST:IF:FREQ respectively, where appropriate.

The following calculation methods will be used.

Using a variable Local Oscillator frequency as set by the command SENS:CONF:MODE:SYST:LOSC VAR: i.e. the DUT has a fixed IF frequency.

Using a fixed Local Oscillator frequency as set by the command SENS:CONF:MODE:SYST:LOSC FIX: i.e. the DUT has a variable IF frequency.

The command will not have any immediate effect if the current frequency measurement mode is fixed, as is set by the command SENS:FREQ:MODE FIX.

RF: = All the above settings for frequency list calculation will calculate the RF frequency for each step. The list of RF frequencies generated will be in the following sequence: Start Frequency, Start Frequency + Step Frequency, Start Frequency + Step Frequency*2, Stop Frequency.

IF: = intermediate frequency

LO: = local oscillator frequency

AMPLifier the DUT is a amplifier and not a frequency converting device

DOWNconv the DUT converts the input frequency to a lower output frequency.

UPConv the DUT converts the input frequency to a higher output frequency.

Example: "SENS:CONF:MODE:DUT AMPL" the DUT is set as an amplifier and is therefore not a frequency converting device.

Characteristics: *RST value: - AMPLifier
SCPI: device-specific

SOURce Subsystem

The SOURce:EXTernal subsystem controls the operation of the unit with option Ext. Generator Control (FSP-B10).

COMMAND	PARAMETERS	UNIT	COMMENT
:SOURce :EXTernal :FREQuency :OFFSet<1 2> [:FACTor] :NUMerator :DENominator :POWer [:LEVel]	<numeric_value> <numeric_value>	Hz DBM	

SOURce:EXTernal:FREQuency:OFFSet<1|2> <numeric value> <numeric value>

This command defines the frequency offset of the selected generator with reference to the receive frequency

Note: Select the frequency offset of the generator so that the frequency range of the generator is not exceeded with the following formula

$$F_{Generator} = F_{Lor} + Offset<1> * \frac{Numerator}{Denominator} + Offset<2>$$

This command is only valid in combination with option Ext. Generator Control R&S FSP-B10.

Example: "SOUR:EXT:FREQ:OFFS 1GHZ" sets a frequency offset of the generator transmit frequency compared to the analyzer receive frequency of 1 GHz.

Characteristics: *RST value: 0 Hz
SCPI: device-specific

SOURce:EXTernal:FREQuency[:FACTor]:NUMerator <numeric value> <numeric value>

This command defines the numerator of the factor with which the analyzer frequency is multiplied in order to obtain the transmit frequency of the selected generator.

Note: Select the multiplication factor in a way that the frequency range of the generator is not exceeded by the following formula

$$F_{Generator} = F_{LO} + Offset<1> * \frac{Numerator}{Denominator} + Offset<2>$$

if applied to the start and stop frequency of the analyzer.

This command is only valid in combination with option Ext. Generator Control R&S FSP-B10.

Example: "SOUR:EXT:FREQ:NUM 4"
"SOUR:EXT:FREQ:DEN 3" sets a multiplication factor of 4/3, i.e. the transmit frequency of the generator is 4/3 times the LO frequency.

Characteristics: *RST value: 1
SCPI: device-specific

SOURce:EXTernal:FREQUENCY[:FACTOR]:DENominator <numeric value> <numeric value>

This command defines the denominator of the factor with which the analyzer frequency is multiplied in order to obtain the transmit frequency of the selected generator.

Note: Select the multiplication factor in a way that the frequency range of the generator is not exceeded by the following formula

$$F_{\text{Generator}} = F_{\text{LO}} + \text{Offset}<1> * \frac{\text{Numerator}}{\text{Denominator}} + \text{Offset}<2>$$

if applied to the start and stop frequency of the analyzer.

This command is only valid in combination with option Ext. Generator Control R&S FSP-B10.

Example: "SOUR:EXT:FREQ:NUM 4"
 "SOUR:EXT:FREQ:DEN 3" sets a multiplication factor of 4/3, i.e. the transmit frequency of the generator is 4/3 times the analyzer frequency.

Characteristics: *RST value: 1
 SCPI: device-specific

SOURce:EXTernal:POWer[:LEVel] <numeric value> <numeric value>

This command sets the output power of the selected generator. This command is only valid in combination with option Ext. Generator Control R&S FSP-B10.

Example: "SOUR:EXT:POW -30dBm" sets the generator level to -30 dBm

Characteristics: *RST value: 5dBm
 SCPI: device-specific

STATus Subsystem

The STATus subsystem contains the commands for the status reporting system (See Section “”). *RST does not influence the status registers.

COMMAND	PARAMETERS	UNIT	COMMENT
:STATus			
:QUEStionable			
:CORRection			
[:EVENT]?	--	--	
:CONDition?	--	--	
:ENABle	0 to 65535	--	
:PTRAnsition	0 to 65535	--	
:NTRAnsition	0 to 65535	--	
:FREQuency			
[:EVENT]?	--	--	
:CONDition?	--	--	
:ENABle	0 to 65535	--	
:PTRAnsition	0 to 65535	--	
:NTRAnsition	0 to 65535	--	
:LIMit			
[:EVENT]?	--	--	
:CONDition?	--	--	
:ENABle	0 to 65535	--	
:PTRAnsition	0 to 65535	--	
:NTRAnsition	0 to 65535	--	

STATus:QUEStionable:CORRection[:EVENT]?

This command queries the contents of the EVENT section of the STATus:QUEStionable:CORRection register. Readout deletes the contents of the EVENT section.

Example: "STAT:QUES:CORR?"

Characteristics: *RST value: -
 SCPI: conforming

STATus:QUEStionable:CORRection:CONDition?

This command queries the contents of the CONDition section of the STATus:QUEStionable:CORRection register. Readout does not delete the contents of the CONDition section.

Example: "STAT:QUES:CORR:COND?"

Characteristics: *RST value: -
 SCPI: conforming

STATus:QUESionable:CORRection:ENABle <numeric value>

This command sets the bits of the ENABLE section of the STATus:QUESionable:CORRection register. The ENABLE register selectively enables the individual events of the associated EVENT section for the summary bit.

Example: "STAT:QUES:CORR:ENAB 65535" All events bits will be represented in the CORRection summary bit.

Characteristics: *RST value: -
SCPI: conforming

STATus:QUESionable:CORRection:PTRansition <numeric value>

This command determines what bits in the STATus:QUESionable:CORRection Condition register will set the corresponding bit in the STATus:QUESionable:CORRection Event register when that bit has a positive transition (0 to 1). The variable <number> is the sum of the decimal values of the bits that are to be enabled.

Example: "STAT:QUES:CORR:PTR 65535" All condition bits will be summarized in the Event register when a positive transition occurs.

Characteristics: *RST value: -
SCPI: conforming

STATus:QUESionable:CORRection:NTRansition <numeric value>

This command determines what bits in the STATus:QUESionable:CORRection Condition register will set the corresponding bit in the STATus:QUESionable:CORRection Event register when that bit has a negative transition (1 to 0). The variable <number> is the sum of the decimal values of the bits that are to be enabled.

Example: "STAT:QUES:CORR:NTR 65535" All condition bits will be summarized in the Event register when a positive transition occurs.

Characteristics: *RST value: -
SCPI: conforming

STATus:QUESionable:FREQuency[:EVENT]?

This command queries the contents of the EVENT section of the STATus:QUESionable:FREQuency register. Readout deletes the contents of the EVENT section.

Example: "STAT:QUES:FREQ?"

Characteristics: *RST value: -
SCPI: conforming

STATus:QUESionable:LIMit[:EVENT]?

This command queries the contents of the EVENT section of the STATus:QUESionable:LIMit register. Readout deletes the contents of the EVENT section.

Example: "STAT:QUES:LIM?"

Characteristics: *RST value: -
 SCPI: conforming

STATus:QUESionable:LIMit:CONDition?

This command queries the contents of the CONDition section of the STATus:QUESionable:LIMit register. Readout does not delete the contents of the CONDition section.

Example: "STAT:QUES:LIM:COND?"

Characteristics: *RST value: -
 SCPI: conforming

STATus:QUESionable:LIMit:ENABLE <numeric value>

This command sets the bits of the ENABLE section of the STATus:QUESionable:LIMit register. The ENABLE register selectively enables the individual events of the associated EVENT section for the summary bit.

Example: "STAT:QUES:CORR:LIM 65535" All events bits will be represented in the LIMit summary bit.

Characteristics: *RST value: -
 SCPI: conforming

STATus:QUESionable:LIMit:PTRansition <numeric value>

This command determines what bits in the STATus:QUESionable:LIMit Condition register will set the corresponding bit in the STATus:QUESionable:LIMit Event register when that bit has a positive transition (0 to 1). The variable <number> is the sum of the decimal values of the bits that are to be enabled.

Example: "STAT:QUES:LIMit:PTR 65535" All condition bits will be summarized in the Event register when a positive transition occurs.

Characteristics: *RST value: -
 SCPI: conforming

STATus:QUESionable:LIMit:NTRansition <numeric value>

This command determines what bits in the STATus:QUESionable:LIMit Condition register will set the corresponding bit in the STATus:QUESionable:LIMit Event register when that bit has a negative transition (1 to 0). The variable <number> is the sum of the decimal values of the bits that are to be enabled.

Example: "STAT:QUES:LIM:NTR 65535" All condition bits will be summarized in the Event register when a positive transition occurs.

Characteristics: *RST value: -
 SCPI: conforming

SYSTEM Subsystem

This subsystem contains a series of commands for general functions.

COMMAND	PARAMETERS	UNIT	COMMENT
.SYSTEM			
:COMMunicate			
:GPIB			
:RDEvice			
:GENerator			
:ADDRess	0..30		
:RDEvice			
:GENerator			
:TYPE	<String>		
:CONFigure			
:GENerator			
:CONTRol			
:STATe	<Boolean>		
:INITialise			
:AUTO	<Boolean>		
:DUT			
:GAIN	<numeric_value>	DB	
:STIMe	<numeric_value>	S	

SYSTEM:COMMunicate:GPIB:RDEvice:GENerator:ADDRess 0 to 30

This command changes the IEC/IEEE-bus address of the external signal generator. The command is only available with option Ext. Generator Control B10.

Example: "SYST:COMM:GPIB:RDEV:GEN1:ADDR 19" Changes the IECBUS address of generator 1 to 19

Characteristics: *RST value: 28
 SCPI: device-specific

SYSTEM:COMMunicate:RDEvice:GENerator:TYPE <name>

This command selects the type of external signal generator. The following table shows the available generator types including the associated interface:

Generator	Generator Min Freq	Generator Max Freq	Generator Min Power dBm	Generator Max Power dBm
SME02	5 kHz	1.5 GHz	-144	+16
SME03	5 kHz	3.0 GHz	-144	+16
SME06	5 kHz	6.0 GHz	-144	+16
SMG	100 kHz	1.0 GHz	-137	+13
SMGL	9 kHz	1.0 GHz	-118	+30
SMGU	100 kHz	2.16 GHz	-140	+13
SMH	100 kHz	2.0 GHz	-140	+13
SMHU	100 kHz	4.32 GHz	-140	+13
SMIQ02B	300 kHz	2.2 GHz	-144	+13
SMIQ02E	300 kHz	2.2 GHz	-144	+13
SMIQ03B	300 kHz	3.3 GHz	-144	+13
SMIQ03E	300 kHz	3.3 GHz	-144	+13
SMIQ04B	300 kHz	4.4 GHz	-144	+10
SMIQ06B	300 kHz	6.4 GHz	-144	+10
SML01	9 kHz	1.1 GHz	-140	+13
SMR20	1 GHz	20 GHz	-130 ²⁾	+11 ²⁾
SMR20B11 ¹⁾	10 MHz	20 GHz	-130 ²⁾	+13 ²⁾
SMR27	1 GHz	27 GHz	-130 ²⁾	+11 ²⁾
SMR27B11 ¹⁾	10 MHz	27 GHz	-130 ²⁾	+12 ²⁾
SMR30	1 GHz	30 GHz	-130 ²⁾	+11 ²⁾
SMR30B11 ¹⁾	10 MHz	30 GHz	-130 ²⁾	+12 ²⁾
SMR40	1 GHz	40 GHz	-130 ²⁾	+9 ²⁾
SMR40B11 ¹⁾	10 MHz	40 GHz	-130 ²⁾	+12 ²⁾
SMP02	10 MHz	20 GHz	-130 ³⁾	+17 ³⁾
SMP03	10 MHz	27 GHz	-130 ³⁾	+13 ³⁾
SMP04	10 MHz	40 GHz	-130 ³⁾	+12 ³⁾
SMP22	10 MHz	20 GHz	-130 ³⁾	+20 ³⁾
SMU200A	100 kHz	2:2 GHz	-145	+13
SMU200B31	100 kHz	2:2 GHz	-145	+19
SMU03	100 kHz	3 GHz	-145	+13
SMU03B31	100 kHz	3 GHz	-145	+19
SMU04	100 kHz	4 GHz	-145	+13
SMU04B31	100 kHz	4 GHz	-145	+19
SMU06	100 kHz	2:2 GHz	-145	+13
SMU06B31	100 kHz	6 GHz	-145	+13
SMT02	5.0 kHz	1.5 GHz	-144	+13
SMT03	5.0 kHz	3.0 GHz	-144	+13
SMT06	5.0 kHz	6.0 GHz	-144	+13
SMX	100 kHz	1.0 GHz	-137	+13
SMY01	9 kHz	1.04 GHz	-140	+13
SMY02	9 kHz	2.08 GHz	-140	+13
HP8340A	10 MHz	26.5 GHz	-110	10
HP ESG-A Series 1000A, 2000A, 3000A, 4000A	250 kHz	4 GHz	-136	20
HP ESG-D SERIES E4432B	250 kHz	3 GHz	-136	+10

¹⁾ Requires mounting of option SMR-B11.

Notes: Generators with TTL interface can also be operated via IECBUS (= GPIB) alone.

The command is only available with option Ext. Generator Control B10.

Example: "SYST:COMM:RDEV:GEN:TYPE 'SME02'" selects SME02 as the external signal generator

Characteristics: *RST value: NONE
SCPI: device-specific

SYSTEM:CONFigure:GENerator:CONTRol:STATe ON | OFF <boolean>

This remote control command is used to specify whether the setup of the external generator is to be automatically controlled by the R&S FS-K30 option (via GPIB) or manually by the user.

Example: "SYST:CONF:GEN:CONT:STAT ON" The R&S FS-K30 option completely controls the setting of the external signal generator.

Characteristics: *RST value: OFF
SCPI: device-specific

SYSTEM:CONFigure:GENerator:INITialise:AUTO ON | OFF:AUTO <boolean>

This remote control command is used to specify whether an initialisation sequence of GPIB commands is sent to an external signal generator prior to performing each measurement. Sending an initialisation sequence before each measurement ensures that the signal generator will be in the correct state to receive control commands during a measurement sequence, however initialising an external signal generator before each measurement adds a time overhead to each measurement.

Example: "SYST:CONF:GEN:INIT:AUT ON" The R&S FS-K30 option initialises the selected signal generator prior to starting each requested measurement.

Characteristics: *RST value: OFF
SCPI: device-specific

SYSTEM:CONFigure:DUT:GAIN <numeric value> <numeric value>

This remote control command allows the maximum gain of the DUT to be specified.

Example: "SYST:CONF:DUT:GAIN 10" The R&S FS-K30 option will expect the gain of the DUT to be 10 dB.

Characteristics: *RST value: 30 dB
SCPI: device-specific

SYSTEM:CONFigure:DUT:STIME <numeric value> <numeric value>

This remote control command allows the DUT settling time to be modified. It represents the time to wait for the DUT to settle after a noise source has been turned on or off.

Example: "SYST:CONF:DUT:STIM 1000MS" The R&S FS-K30 option will wait for a period of one second for the DUT to settle down after exposure to the noise source has been removed.

Characteristics: *RST value: 50 milliseconds
SCPI: device-specific

Status reporting registers

The status reporting system (see Fig. 3-1) stores all information on the present operating state of the instrument, e.g. that the instrument presently carries out a calibration and on errors which have occurred. This information is stored in the status registers and in the error queue. The status registers and the error queue can be queried via IEC bus.

The information is of a hierarchical structure. The register status byte (STB) defined in IEEE 488.2 and its associated mask register service request enable (SRE) form the uppermost level. The STB receives its information from the standard event status register (ESR) which is also defined in IEEE 488.2 with the associated mask register standard event status enable (ESE) and registers STATus:OPERation and STATus:QUEStionable which are defined by SCPI and contain detailed information on the instrument.

The IST flag ("Individual SStatus") and the parallel poll enable register (PPE) allocated to it are also part of the status reporting system. The IST flag, like the SRQ, combines the entire instrument status in a single bit. The PPE fulfils the same function for the IST flag as the SRE for the service request.

The output buffer contains the messages the instrument returns to the controller. It is not part of the status reporting system but determines the value of the MAV bit in the STB and thus is represented in

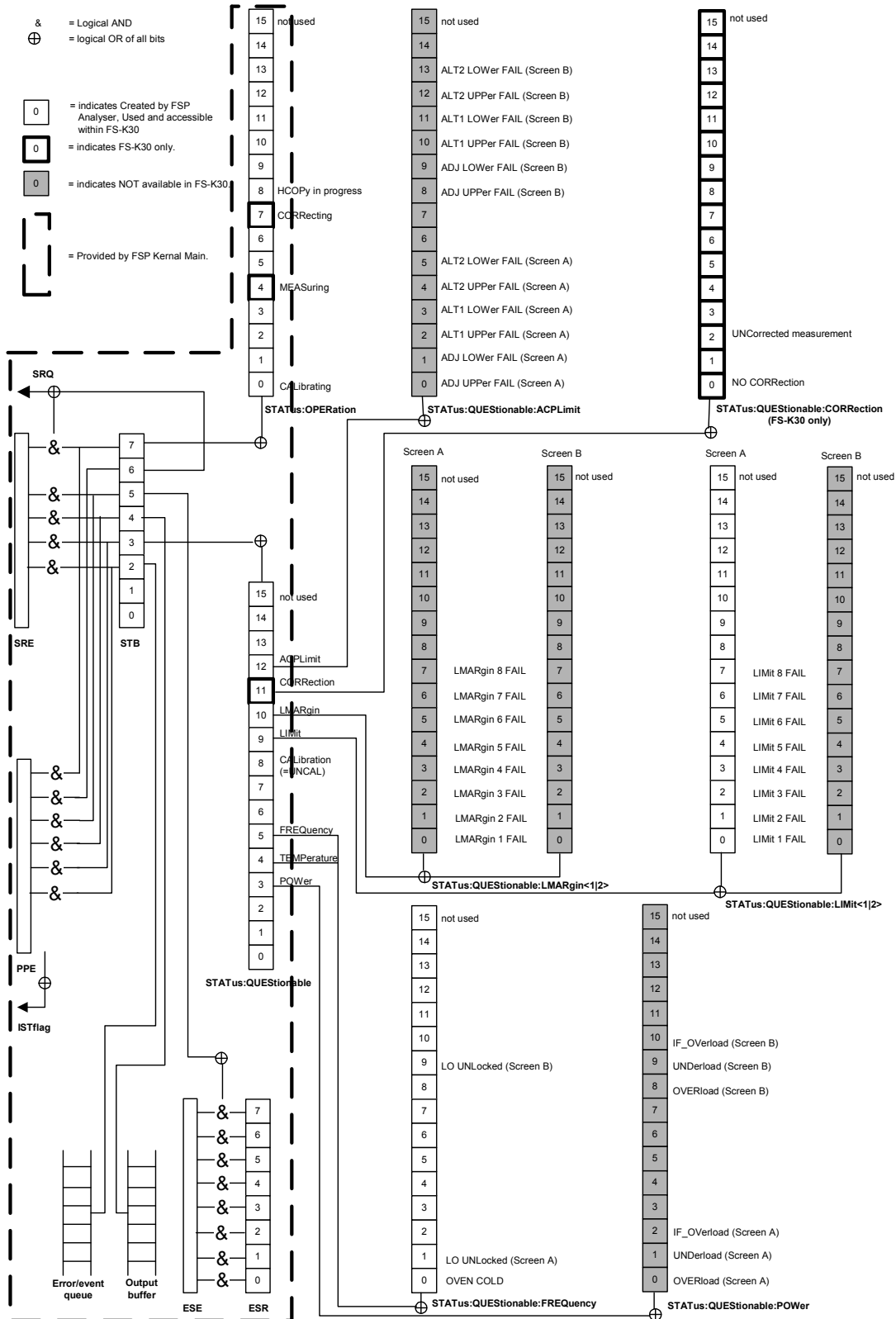

Fig. 3-1 Overview of the status registers

Description of the Status Registers

All the status registers shown in Fig. 3-1 are the same as those provided by the base system, with the exception of the following:

- **STATus:OPERation** – Although this register is provided by R&S FSP Kernel main, R&S FS-K30 makes use of bits 4 & 7 in this register which are not used within R&S FSP Kernel main
- **STATus:QUESTionable** - Although this register is provided by R&S FSP Kernel main, R&S FS-K30 makes use of bit 11 in this register which is not used within R&S FSP Kernel main.
- **STATus:QUESTionable:ACPLimit** – This register is provided by the analyser and is not available from the R&S FS-K30 command tree
- **STATus:QUESTionable:LIMit2** – This register is provided by the analyser and is not available from the R&S FS-K30 command tree
- **STATus:QUESTionable:LMARgin<1|2>** – These registers are provided by the analyser and are not available from the R&S FS-K30 command tree
- **STATus:QUESTionable:POWER** – This register is provided by the analyser and is not available from the R&S FS-K30 command tree
- **STATus:QUESTionable:CORRection** – This register is provided by the R&S FS-K30 option itself.

The deviations from the status register structure of the base system are detailed below.

STATus:OPERation Register

In the **CONDition** part, this register contains information on which actions the instrument is being executing or, in the **EVENT** part, information on which actions the instrument has executed since the last reading. It can be read using commands "**STATus:OPERation:CONDition?**" or "**STATus:OPERation[:EVENT]?**".

Bit No	Meaning
0	CALibrating This bit is set as long as the instrument is performing a calibration.
1 to 3	These bits are not used
4	MEASuring A '1' in this bit position indicates that a measurement is in progress. R&S FS-K30 only
5 to 6	These bits are not used
7	CORRecting Indicates that a user calibration is in progress. R&S FS-K30 only
8	HardCOPy in progress This bit is set while the instrument is printing a hardcopy.
9 to 14	These bits are not used
15	This bit is always 0

STATus:QUEStionable Register

This register comprises information about indefinite states which may occur if the unit is operated without meeting the specifications. It can be queried by commands `STATus:QUEStionable:CONDition?` and `STATus:QUEStionable[:EVENT]?`.

Bit No	Meaning
0 to 2	These bits are not used
3	POWER This bit is set if a questionable power occurs (cf. also section "STATus:QUEStionable:POWer Register").
4	TEMPerature This bit is set if a questionable temperature occurs.
5	FREQuency The bit is set if a frequency is questionable (cf. section "STATus:QUEStionable:FREQuency Register").
6 to 7	These bits are not used
8	CALibration The bit is set if a measurement is performed uncalibrated (= ^ label "UNCAL")
9	LIMit (device-specific) This bit is set if a limit value is violated (see also section STATus:QUEStionable:LIMit Register)
10	LMARgin (device-specific) This bit is set if a margin is violated (see also section STATus:QUEStionable:LMARgin Register)
11	CORRection This bit is set if a questionable correction data occurs (see also section STATus:QUEStionable:CORRection. R&S FS-K30 only)
12	ACPLimit This bit is set if a limit for the adjacent channel power measurement is violated (see also section "STATus:QUEStionable:ACPLimit Register").
13 to 14	These bits are not used
15	This bit is always 0

STATus:QUEStionable:CORRection Register

This register comprises information about the correction state of noise measurements in R&S FS-K30. It can be queried by commands `STATus:QUEStionable:CONDition?` and `STATus:QUEStionable[:EVENT]?`.

Bit No	Meaning
0	NO CORRection User calibration is required (i.e. not done, or setup changed). Will remain 1 until a user calibration is done. Set to 1 at the start of a user calibration. It will go to 0 at the end of a user calibration only if at least all points on one range have been calibrated. Initial value is 1.
1	These bits are not used
2	UNCorrected measurement Uncorrected measurement data (one or more points could not be corrected using existing user calibration). Set to 0 at the start of each sweep/redisplay of result. Will remain zero until an attempt is made to correct a point and the calibration data does not exist (the required range has not been calibrated). Note that if no user calibration data exists, this bit will not be set when an attempt is made to make a corrected measurement — use Bit 0 to determine if a corrected measurement can be attempted.
3 to 14	These bits are not used
15	This bit is always 0

Error Reporting

Error reporting for the K30 option is carried out using the Service Request (SRQ) interrupt in the GPIB interface. When an error occurs a Service Request interrupt will be generated. The master can then query the slave instrument for the error that triggered the interrupt. Errors are queried through the "SYSTem:ERRor" command.

4 List of Warnings & Error Messages

The list of possible warning & error messages are shown below :

Status Bar Message	Description
Frequency list truncated, max 100 entries	The settings for start, stop and step frequencies would require a frequency list greater than 100 entries. The list calculated is terminated at the 100 th entry. Try using a larger step size of splitting the test up into a series of frequency list tests.
Missing [ENR][, &][LossIn][, &][LossOut] for meas.freq.	No ENR, Loss In and/or Loss Out can be determined for one or all of the measurement frequencies. This occurs when using tables of ENR, Loss In and/or Loss out values. Check that the frequency ranges of the tables covers the range of frequencies to be measured. For each measurement frequency where ENR, Loss In or Loss Out cannot be determined 0 is used.
Generator connection error	No connection could be made to the external signal generator. Check the connection between the analyzer and the signal generator. Also check that the correct GPIB address has been specified for the signal generator.
Generator not initialised	The external signal generator has not been initialised and as such cannot be controlled by the spectrum analyzer. The signal generator can be initialised manually by pressing the <i>INIT GEN</i> soft-key or can automatically be initialised by selecting the <i>init before meas</i> field in the <i>SET MEAS</i> view
Generator frequency out of range	The LO frequency to be used for a measurement point is out of range for the selected signal generator. Reduce the LO frequency or use a signal generator with the required frequency range.

5 Index

- (Key)	1.14	Gain Trace Min Y-Axis	2.36
0		Gain Trace Symbols	2.37
0 to 9 (Key)	1.14	Gain Trace Y-Axis	2.36
2		Generator Automatic Control	2.20
2nd Stage Correction	2.16	Generator Frequency	2.22
A		Generator Level	2.21
Automatic Ref Level	2.18	Generator Select	2.21
Average	2.18	GPIB Address	2.21
C		H	
Calibration	1.7	Hardkey	
Combined Trace Display	2.33	AMPT	1.13
Connecting the noise source	1.7, 1.8, 2.4	DISP	1.13
CTRL (Key)	1.14	FILE	1.13
Cursor (Keys)	1.14, 1.16	FREQ	1.13
D		HCOPI	1.13
DISPlay[:WINDow<1>]:TABLE		MEAS	1.13
<Boolean>	3.16	MKR	1.13
DUT	2.1	MKR->	1.13
Amplifier	1.8, 2.2	PRESET	1.13
Frequency Converter	2.3	SWEEP	1.13
Large Gain	2.38	TRACE	1.13
E		Hardkeys	1.13
Edit		Hotkey	1.9
Checkbox Value	1.21	CAL	1.10
Enumerated Value	1.20	FIX FREQ	1.10
Numeric Value	1.18	NOISE	1.10
ENR	2.23	RUN CONT	1.10
ENR Constant	2.24	RUN SGL	1.10
ENR Selection	2.24	SPECTRUM	1.10
ENR Table	2.25	I	
Delete	2.26	Image Rejection	2.12
Insert	2.26	Image-frequency Rejection	2.39
ENTER (Key)	1.14	Init before meas	2.21
Error Reporting	3.45	INPut:GAIN:STATe	
ESC (Key)	1.14	ON OFF	3.21
Exiting the application	1.4	INPut:PRESelection[:STATe]	
F		ON OFF	3.21
Fixed IF	2.12	Installation	1.2
Fixed LO	2.12	INSTRument:NSElect	
Frequency Table	2.13	<numeric_value> %f	3.22
Delete	2.13	Introduction	1.2
Insert	2.13	K	
Function Keys	1.14	Keyboard	1.14
G		L	
Gain		Limit Line	1.26
Large	2.38	Adding	1.27
Gain Trace Automatic Scaling	2.36	Deleting	1.30
Gain Trace Max Y-Axis	2.36	Enabling/Disabling	1.30
		Modifying	1.29
		Limit Table	1.28
		Delete	1.28
		Insert	1.28
		Loss input	2.27
		Loss Input	2.28
		Loss Input Constant	2.28
		Loss Input Selection	2.28
		Loss Input Table	2.29
		Delete	2.30

Insert.....	2.29
Loss output.....	2.27
Loss Output.....	2.30
Loss Output Constant.....	2.30
Loss Output Selection.....	2.30
Loss Output Table.....	2.31
Delete.....	2.32
Insert.....	2.32

M

Marker	
Adjusting.....	1.33
Assigning to trace.....	1.34
Toggle Display.....	1.34
Marker Menu.....	1.33
Measurement.....	2.1
Calibration.....	2.4
Direct.....	2.2
Fixed Frequency.....	2.5, 2.9
Frequency List.....	2.5, 2.6
Frequency-converting.....	2.3, 2.39
Harmonics Mixer.....	2.41
Mixer with an Average Sideband Suppression.....	2.40
Mixer with Unknown Sideband Suppression.....	2.41
Mixer without Sideband Suppression.....	2.40
Results.....	2.6
Running.....	2.5
Single-Sideband Mixer.....	2.40
Measurement Mode.....	2.12
MKR Menu.....	1.35
Mouse.....	1.15

N

Navigation.....	1.9
Tables.....	1.22
Noise Trace Symbols.....	2.36
Noise Trace Automatic Scaling.....	2.35
Noise Trace Max Y-Axis NF.....	2.35
Noise Trace Max Y-Axis Temp.....	2.36
Noise Trace Min Y-Axis NF.....	2.35
Noise Trace Min Y-Axis Temp.....	2.35
Noise Trace Y-Axis.....	2.35
Numeric Keypad.....	1.15

P

Parameters	
Selecting & Editing.....	1.15
Selection using external keyboard.....	1.17
Selection using mouse.....	1.17
Pre-amplifier.....	2.20
Pre-selector.....	2.19
Printing.....	1.25

Q

Quick Start.....	1.5
------------------	-----

R

Range.....	2.19
RBW.....	2.17
Ref Level.....	2.19
RF Attenuation.....	2.18
Rollkey.....	1.16
Room Temperature.....	2.24

S

Save/Recall.....	1.24
Schematic.....	2.14
Settings	
ENR.....	2.23
Frequency.....	2.10
Graphic.....	2.33
Loss.....	2.27
Measurement.....	2.15
Settling Time.....	2.17
Sideband suppression.....	2.39
Softkey.....	1.11
BUILD LST.....	2.13
ENR.....	2.23
GRAPHIC.....	2.33
INIT GEN.....	2.21
LOSS.....	2.27
SCHEMATIC.....	2.14
SET FREQ.....	2.10
SET MEAS.....	2.15
Start Frequency.....	2.11
Starting the application.....	1.4
Status Bar.....	1.23
Status registers.....	3.42
Step Frequency.....	2.11
Stop Frequency.....	2.11
Sweep Time.....	2.17

T

Title Bar.....	1.23
Trace Menu.....	1.31

V

Voltage supply of noise source.....	1.7, 2.4
-------------------------------------	----------

W

Warnings & Error Messages.....	4.1
--------------------------------	-----

X

X-Axis.....	2.37
-------------	------